



**Lexington County School District
One**

INVITATION FOR BIDS

Solicitation
Number:
Date Issued:
Procurement
Officer:
Phone:
E-Mail Address:

B2024.3
01/31/2024
Elizabeth Marsh, CPPB,
NIGP-CPP
(803) 821-1176
emarsh@lexington1.net

DESCRIPTION: SYNTHETIC TURF REPLACEMENT RIVER BLUFF HIGH SCHOOL

The Term "Offer" Means Your "Bid" or "Proposal". Your offer must be submitted in a sealed package. Solicitation Number & Opening Date must appear on package exterior. See "Submitting Your Offer" provision.

SUBMIT YOUR SEALED OFFER TO THE FOLLOWING ADDRESSES BELOW:

PHYSICAL/MAILING ADDRESS:
Lexington School District One
Attn: Procurement Services
100 Tarrar Springs Road
Lexington, South Carolina 29072

SUBMIT OFFER BY (Opening
Date/Time): **03/13/2024, 3:00 PM ET**
(See "Deadline For Submission Of Offer"
provision)

QUESTIONS MUST BE RECEIVED BY:
02/09/2024, 1:00 PM ET (See "Questions From
Offerors" provision)

NUMBER OF COPIES TO BE SUBMITTED: One Original Copy & One Digital Copy on USB Drive

CONFERENCE TYPE: **Pre-Bid Meeting & Site Visit** LOCATION: River Bluff High School ,
DATE & TIME: **2/07/2024 10:00 AM ET** 320 Corley Mill Road ,Lexington, SC 29072
(As appropriate, see "Conferences - Pre-Bid/Proposal" & "Site Visit" provisions)

AWARD & AMENDMENTS Award will be posted at the Physical Address above on **03/22/2024**. The award, notice of this solicitation, any amendments, and any related notices will be posted at the following web address:
<https://www.lexington1.net/Page/4030>

You must submit a signed copy of this form with Your Offer. By submitting a bid or proposal, You agree to be bound by the terms of the Solicitation. You agree to hold Your Offer open for a minimum of 60 calendar days after the Opening Date. (See "Signing Your Offer" provisions.)

NAME OF OFFEROR:
(full legal name of business submitting the offer)

OFFEROR'S TYPE OF ENTITY:
(Check one)

AUTHORIZED SIGNATURE:
(Person must be authorized to submit binding offer to contract on behalf of Offeror.)

- Sole Proprietorship
- Partnership
- Corporate entity (not tax-exempt)
- Tax exempt corporate entity
- Government entity (federal, state, or local)
- Other _____

TITLE:
(business title of person signing above)

PRINTED NAME:
(printed name of person signing above)

DATE SIGNED:

(See "Signing your Offer" provision)

Email Address:

INSTRUCTIONS REGARDING OFFEROR'S NAME: Any award issued will be issued to, and the contract will be formed with, the entity identified as the Offeror. The entity named as the Offeror must be a single and distinct legal entity. Do not use the name of a branch office or a division of a larger entity if the branch or division is not a separate legal entity, i.e., a separate corporation, partnership, sole proprietorship, etc.

STATE OF INCORPORATION

(If you are a corporation, identify the state of incorporation.)

TAXPAYER IDENTIFICATION NO.

(See "Taxpayer Identification Number" provision)

PAGE TWO
(Return Page Two with Your Offer)

<p>HOME OFFICE ADDRESS (Address for Offeror's home office principal place of business)</p> <p>___ Payment Address same as Home Office Address ___ Payment Address same as Notice Address (check only one)</p>	<p>NOTICE ADDRESS (Address to which all procurement and contract related notices should be sent.) (See "Notice" clause)</p> <table border="1" style="width:100%; border-collapse: collapse;"> <tr> <td style="width:15%;">Area Code:</td> <td style="width:25%;">Number:</td> <td style="width:15%;">Extension:</td> <td style="width:45%;">Facsimile:</td> </tr> </table> <table border="1" style="width:100%; border-collapse: collapse;"> <tr> <td style="padding: 2px;">Email Address:</td> </tr> </table>	Area Code:	Number:	Extension:	Facsimile:	Email Address:
Area Code:	Number:	Extension:	Facsimile:			
Email Address:						
<p>PAYMENT ADDRESS (Address to which payments will be sent.) (See "Payment" clause)</p> <p>___ Payment Address same as Home Office Address ___ Payment Address same as Notice Address (check only one)</p>	<p>ORDER ADDRESS (Address to which purchase orders will be sent) (See "Purchase Orders and "Contract Documents" clauses)</p> <p>___ Order Address same as Home Office Address ___ Order Address same as Notice Address (check only one)</p>					

<p>ACKNOWLEDGMENT OF AMENDMENTS Offerors acknowledge receipt of amendments by indicating amendment number and its date of issue. (See "Amendments to Solicitation" Provision)</p>							
Amendment No.	Amendment Issue Date	Amendment No.	Amendment Issue Date	Amendment No.	Amendment Issue Date	Amendment No.	Amendment Issue Date

<p>DISCOUNT FOR PROMPT PAYMENT (See "Discount for Prompt Payment" clause)</p>	10 Calendar Days (%)	20 Calendar Days (%)	30 Calendar Days (%)	___ Calendar Days (%)
---	----------------------	----------------------	----------------------	-----------------------

<p>MINORITY PARTICIPATION</p> <p>Please answer the following question:</p> <p>Are you certified as a MOB/WOB (minority-owned business/woman-owned business) by the State of South Carolina?</p> <p><input type="checkbox"/> Yes <input type="checkbox"/> No</p> <p>If yes, provide certification number: _____.</p>
--

TABLE OF CONTENTS

I.	Scope of Solicitation
II.	Instructions to Offerors
	A. General Instructions
	B. Special Instructions
III.	Scope of Work / Specifications
IV.	Information for Offerors to Submit
V.	Qualifications
VI.	Award Criteria
VII.	Terms and Conditions
	A. General
	B. Special & Liquidated Damages
VIII.	Bidding Schedule
X	Subcontractor Information
XI.	Attachments to Solicitation

I. SCOPE OF SOLICITATION

Lexington County School District One is soliciting competitive sealed bids from qualified sources to replace the synthetic turf at River Bluff High School.

ACQUIRE SERVICES: The purpose of this solicitation is to provide services complying with the enclosed description and/or specifications and conditions.

II. INSTRUCTIONS TO OFFERORS - A. GENERAL INSTRUCTIONS

AMENDMENTS TO SOLICITATION: (a) The Solicitation may be amended at any time prior to opening. All actual and prospective Offerors should monitor the following web site for the issuance of Amendments: <http://www.lexington1.net/departments/procurement/solicitations-and-awards> (b) Offerors shall acknowledge receipt of any amendment to this solicitation (1) by signing and returning the amendment, (2) by identifying the amendment number and date in the space provided for this purpose on Page Two, (3) by letter, or (4) by submitting a bid that indicates in some way that the bidder received the amendment. (c) If this solicitation is amended, then all terms and conditions which are not modified remain unchanged.

AWARD NOTIFICATION: Notice regarding any award, cancellation of award, or extension of award will be posted at the location and on the date specified on the Cover Page or, if applicable, any notice of extension of award. Should the contract resulting from this Solicitation have a total or potential value in excess of fifty thousand dollars, such notice will be sent electronically to all Offerors responding to the Solicitation and any award will not be effective until the calendar day (including weekends and holidays) immediately following the seventh business day after such notice is given.

BID / PROPOSAL AS OFFER TO CONTRACT: By submitting Your Bid or Proposal, You are offering to enter into a contract with the District. Without further action by either party, a binding contract shall result upon final award. Any award issued will be issued to, and the contract will be formed with, the entity identified as the Offeror on the Cover Page. An Offer may be submitted by only one legal entity; "joint bids" are not allowed.

BID ACCEPTANCE PERIOD: In order to withdraw Your Offer after the minimum period specified on the Cover Page, You must notify the Procurement Officer in writing.

BID IN ENGLISH & DOLLARS: Offers submitted in response to this solicitation shall be in the English language and in US dollars, unless otherwise permitted by the Solicitation.

CERTIFICATE OF INDEPENDENT PRICE DETERMINATION:

GIVING FALSE, MISLEADING, OR INCOMPLETE INFORMATION ON THIS CERTIFICATION MAY RENDER YOU SUBJECT TO PROSECUTION UNDER SECTION 16-9-10 OF THE SOUTH CAROLINA CODE OF LAWS AND OTHER APPLICABLE LAWS.

(a) By submitting an offer, the Offeror certifies that-

(1) The prices in this offer have been arrived at independently, without, for the purpose of restricting competition, any consultation, communication, or agreement with any other Offeror or competitor relating to-

(i) Those prices;

(ii) The intention to submit an offer; or

(iii) The methods or factors used to calculate the prices offered.

(2) The prices in this offer have not been and will not be knowingly disclosed by the Offeror, directly or indirectly, to any other Offeror or competitor before bid opening (in the case of a sealed bid solicitation) or contract award (in the case of a negotiated solicitation) unless otherwise required by law; and

(3) No attempt has been made or will be made by the Offeror to induce any other concern to submit or not to submit an offer for the purpose of restricting competition.

(b) Each signature on the offer is considered to be a certification by the signatory that the signatory-

(1) Is the person in the Offeror's organization responsible for determining the prices being offered in this bid or proposal, and that the signatory has not participated and will not participate in any action contrary to paragraphs (a)(1) through (a)(3) of this certification; or

(2)(i) Has been authorized, in writing, to act as agent for the Offeror's principals in certifying that those principals have not participated, and will not participate in any action contrary to paragraphs (a)(1) through (a)(3) of this certification [As used in this subdivision (b)(2)(i), the term "principals" means the person(s) in the Offeror's organization responsible for determining the prices offered in this bid or proposal];

(ii) As an authorized agent, does certify that the principals referenced in subdivision (b)(2)(i) of this certification have not participated, and will not participate, in any action contrary to paragraphs (a)(1) through (a)(3) of this certification; and (iii) As an agent, has not personally participated, and will not participate, in any action contrary to paragraphs (a)(1) through (a)(3) of this certification.

(c) If the Offeror deletes or modifies paragraph (a)(2) of this certification, the Offeror must furnish with its offer a signed statement setting forth in detail the circumstances of the disclosure. [02-2A032-1]

CERTIFICATION REGARDING DEBARMENT AND OTHER RESPONSIBILITY MATTERS:

(a)(1) By submitting an Offer, Offeror certifies, to the best of its knowledge and belief, that-

(i) Offeror and/or any of its Principals-

(A) Are not presently debarred, suspended, proposed for debarment, or declared ineligible for the award of contracts by any state or federal agency;

(B) Have not, within a three-year period preceding this offer, been convicted of or had a civil judgment rendered against them for: commission of fraud or a criminal offense in connection with obtaining, attempting to obtain, or performing a public (Federal, state, or local) contract or subcontract; violation of Federal or state antitrust statutes relating to the submission of offers; or commission of embezzlement, theft, forgery, bribery, falsification or destruction of records, making false statements, tax evasion, or receiving stolen property; and

(C) Are not presently indicted for, or otherwise criminally or civilly charged by a governmental entity with, commission of any of the offenses enumerated in paragraph (a)(1)(i)(B) of this provision.

(ii) Offeror has not, within a three-year period preceding this offer, had one or more contracts terminated for default by any public (Federal, state, or local) entity.

(2) "Principals," for the purposes of this certification, means officers; directors; owners; partners; and, persons having primary management or supervisory responsibilities within a business entity (e.g., general manager; plant manager; head of a subsidiary, division, or business segment, and similar positions).

(b) Offeror shall provide immediate written notice to the Procurement Officer if, at any time prior to contract award, Offeror learns that its certification was erroneous when submitted or has become erroneous by reason of changed circumstances. (c) If Offeror is unable to certify the representations stated in paragraphs (a)(1), Offer must submit a written explanation regarding its inability to make the certification. The certification will be considered in connection with a review of the Offeror's responsibility. Failure of the Offeror to furnish additional information as requested by the Procurement Officer may render the Offeror non-responsible.

(d) Nothing contained in the foregoing shall be construed to require establishment of a system of records in order to render, in good faith, the certification required by paragraph (a) of this provision. The knowledge and information of an Offeror is not required to exceed that which is normally possessed by a prudent person in the ordinary course of business dealings. (e) The certification in paragraph (a) of this provision is a material representation of fact upon which reliance was placed when making an award. If it is

later determined that the Offeror knowingly or in bad faith rendered an erroneous certification, in addition to other remedies available to the District, the Procurement Officer may terminate the contract resulting from this solicitation for default.

CIVIL RIGHTS PROVISIONS: The contractor providing services under this Invitation to Bid must comply with the provisions of the Civil Rights Act of 1964, as amended. The contractor must comply with applicable federal, state, and local laws and regulations pertaining to wages, hours, and conditions of employment. In connection with contractor's performance of work under this contract, contractor agrees not to discriminate against any employee(s) or applicant(s) for employment because of race, color, national origin, sex, age, or disability. In accordance with Federal law and U.S. Department of Agriculture policy, this institution is prohibited from discriminating on the basis of race, color, national origin, sex, age or disability. To file a complaint, write USDA, Director, Office of Adjudication, 1400 Independence Avenue, SW, Washington, DC 20250-9410 or call toll free at (866) 632-9992. Individuals who are hearing impaired or have speech disabilities may contact USDA through the Federal Relay Service at 800-877-8339; of 800-845-6136 (Spanish). USDA is an equal opportunity provider and employer.

CODE OF LAWS AVAILABLE: The South Carolina Code of Laws is available at <https://www.scstatehouse.gov/code/statmast.php>
The District's Procurement Code is available at:
https://www.lexington1.net/cms/lib/SC50000473/Centricity/Domain/1592/Procurement_Code.pdf

CONTRACT VIOLATION: During the term of the contract, contractors who violate any contract will be considered in breach and subject to cancellation for cause. Contractors may be suspended or debarred from doing business with the District. Examples of vendor violations include, but are not limited to: (1) Adding items to the contract without approval. (2) Increasing contract price without approval. (3) Misrepresentation of the contract to any District entity.

COMPLETION OF FORMS / CORRECTION OF ERRORS: All prices and notations should be printed in ink or typewritten. Errors should be crossed out, corrections entered and initialed by the person signing the bid. Do not modify the solicitation document itself including the bid schedule.

DEADLINE FOR SUBMISSION OF OFFER: Any offer received after the Procurement Officer or his designee has declared that the time set for opening has arrived, shall be rejected unless the offer has been delivered to the designated Procurement Office or the District Office's mail room which services that Procurement Office prior to the bid opening which is located at the physical address on the first page of the solicitation.

DEFINITIONS: EXCEPT AS OTHERWISE PROVIDED HEREIN, THE FOLLOWING DEFINITIONS ARE APPLICABLE TO ALL PARTS OF THE SOLICITATION.

AMENDMENT – means a document issued to supplement the original solicitation document.

BOARD – means the Lexington School District One Board of Trustees.

BUYER – means the Procurement Officer.

CHANGE ORDER - means any written alteration in specifications, delivery point, rate of delivery, period of performance, price, quantity, or other provisions of any contract accomplished by mutual agreement of the parties to the contract. CONTRACT - See clause entitled "Contract Documents & Order of Precedence."

CONTRACT MODIFICATION – means a written order signed by the Procurement Officer, directing the contractor to make changes which the changes clause of the contract authorizes the Procurement Officer to order without the consent of the contractor.

CONTRACTOR - means the Offeror receiving an award as a result of this solicitation.

COVER PAGE – means the top page of the original solicitation on which the solicitation is identified by number. Offerors are cautioned that Amendments may modify information provided on the Cover Page.

DISTRICT – means Lexington County School District One.

OFFER – means the bid or proposal submitted in response to this solicitation. The terms "Bid" and "Proposal" are used interchangeably with the term "Offer."

OFFEROR – means the single legal entity submitting the offer. The term "Bidder" is used interchangeably with the term "Offeror." See bidding provisions entitled "Signing Your Offer" and "Bid/Proposal As Offer To Contract." PAGE TWO

– means the second page of the original solicitation, which is labeled Page Two.

PROCUREMENT OFFICER – means the person, or his successor, identified as such on the Cover Page.

SOLICITATION – means this document, including all its parts, attachments, and any Amendments.

SUBCONTRACTOR – means any person having a contract to perform work or render service to Contractor as a part of the Contractor's agreement arising from this solicitation.

WORK - means all labor, materials, equipment, services, or property of any type, provided or to be provided by the Contractor to fulfill the Contractor's obligations under the Contract.

YOU and YOUR – means Offeror.

DRUG FREE WORKPLACE CERTIFICATION: By submitting an Offer, Contractor certifies that, if awarded a contract, Contractor will comply with all applicable provisions of The Drug-free Workplace Act, Title 44, Chapter 107 of the South Carolina Code of Laws, as amended.

DUTY TO INQUIRE: Offeror, by submitting an Offer, represents that it has read and understands the Solicitation and that its Offer is made in compliance with the Solicitation. Offerors are expected to examine the Solicitation thoroughly and should request an explanation of any ambiguities, discrepancies, errors, omissions, or conflicting statements in the Solicitation. Failure to do so will be at the Offeror's risk. Offeror assumes responsibility for any patent ambiguity in the Solicitation that Offeror does not bring to the District's attention.

ETHICS ACT: Ethics Certificate: By submitting an offer, the Offeror certifies that the Offeror has and will comply with, and has not, and will not, induce a person to violate Title 8, Chapter 13 of the South Carolina Code of Laws, as amended (ethics act). The following statutes require special attention: Section 8-13-700, regarding use of official position for financial gain; Section 8-13-705, regarding gifts to influence action of public official; Section 8-13-720, regarding offering money for advice or assistance of public official; Sections 8-13-755 and 8-13-760, regarding restrictions on employment by former public official; Section 8-13-775, prohibiting public official with economic interests from acting on contracts; Section 8-13-790, regarding recovery of kickbacks; Section 8-13-1150, regarding statements to be filed by consultants; and Section 8-13-1342, regarding restrictions on contributions by contractor to candidate who participated in awarding of contract. The state may rescind any contract and recover all amounts expended as a result of any action taken in violation of this provision. If contractor participates, directly or indirectly, in the evaluation or award of public contracts, including without limitation, change orders or task orders regarding a public contract, contractor shall, if required by law to file such a statement, provide the statement required by Section 8-13-1150 to the procurement officer at the same time the law requires the statement to be filed.

OMIT TAXES FROM PRICE: Do not include any sales or use taxes in Your price that the District may be required to pay.

OPEN TRADE REPRESENTATION: By submitting an Offer, Offeror represents that Offeror is not currently engaged in the boycott of a person or an entity based in or doing business with a jurisdiction with whom South Carolina can enjoy open trade, as defined in SC Code Section 11-35-5300.

PROHIBITED COMMUNICATIONS AND DONATIONS: Violation of these restrictions may result in disqualification of your offer, suspension or debarment, and may constitute a violation of law. (a) During the period between publication of the solicitation and final award, *you must not communicate, directly or indirectly, with the District or its employees, agents or officials regarding any aspect of this procurement activity*, unless otherwise approved in writing by the Procurement Officer. (b) You are advised to familiarize yourself with Regulation 19-445.2165, which restricts donation to a governmental entity with whom you have or seek to have a contract. You represent that your offer discloses any gifts made, directly or through an intermediary, by you or your named subcontractors to or for the benefit of the District during the period beginning eighteen months prior to the opening date.

PROTESTS: Any prospective bidder, Offeror, contractor, or subcontractor who is aggrieved in connection with the solicitation of a contract shall protest within fifteen days of the date of issuance of the applicable solicitation document at issue. Any actual bidder, Offeror, contractor, or subcontractor who is aggrieved in connection with the intended award or award of a contract shall protest within ten days of the date notification of award is posted in accordance with this code. A protest shall be in writing, submitted to the appropriate Chief Procurement Officer, and shall set forth the grounds of the protest and the relief requested with enough particularity to give notice of the issues to be decided. [Article 17 - 4210 of the District's Procurement Code] The rights and remedies granted under Article 17 – 4210.1.2 are not available for contracts with an actual or potential value of up to fifty thousand dollars.

PUBLIC OPENING: Offers will be publicly opened at the date / time and at the location identified on the Cover Page, or last Amendment, whichever is applicable.

QUESTIONS FROM OFFERORS: (a) Any prospective Offeror desiring an explanation or interpretation of the solicitation, drawings, specifications, etc., must request it in writing. Questions must be received by the Procurement Officer no later than five (5) days prior to opening unless otherwise stated on the Cover Page. Label any communication regarding your questions with the name of the procurement officer, and the solicitation's title and number. Oral explanations or instructions will not be binding. Any information given a prospective Offeror concerning a solicitation will be furnished promptly to all other prospective Offerors as an Amendment to the solicitation, if that information is necessary for submitting offers or if the lack of it would be prejudicial to other prospective Offerors. (b) The District seeks to permit maximum practicable competition. Offerors are urged to advise the

Procurement Officer – as soon as possible – regarding any aspect of this procurement, including any aspect of the Solicitation that unnecessarily or inappropriately limits full and open competition.

All questions shall be in writing and submitted to, and received no later than the date/time for submission of questions as stated on Cover Page of this document, via e-mail to:

Email: emarsh@lexington1.net with Subject Line: Solicitation # (as on the Cover Page of this document)

REJECTION/CANCELLATION: The District may cancel this solicitation in whole or in part. The District may reject any or all proposals in whole or in part. [Article 5 - 1710 of the District's Procurement Code]

RESPONSIVENESS / IMPROPER OFFERS:

(a) Bid as Specified. Offers for supplies or services other than those specified will not be considered unless authorized by the Solicitation.

(b) Multiple Offers. Offerors may submit more than one Offer, provided that each Offer has significant differences other than price. Each separate Offer must satisfy all Solicitation requirements. If this solicitation is an Invitation for Bids, each separate offer must be submitted as a separate document. If this solicitation is a Request for Proposals, multiple offers may be submitted as one document, provided that you clearly differentiate between each offer and you submit a separate cost proposal for each offer, if applicable.

(c) Responsiveness. Any Offer which fails to conform to the material requirements of the Solicitation may be rejected as nonresponsive. Offers which impose conditions that modify material requirements of the Solicitation may be rejected. If a fixed price is required, an Offer will be rejected if the total possible cost to the District cannot be determined. Offerors will not be given an opportunity to correct any material nonconformity. Any deficiency resulting from a minor informality may be cured or waived at the sole discretion of the Procurement Officer.

(d) Price Reasonableness: Any offer may be rejected if the Procurement Officer determines in writing that it is unreasonable as to price.

(e) Unbalanced Bidding. The District may reject an Offer as nonresponsive if the prices bid are materially unbalanced between line items or sub-line items. A bid is materially unbalanced when it is based on prices significantly less than cost for some work and prices which are significantly overstated in relation to cost for other work, and if there is a reasonable doubt that the bid will result in the lowest overall cost to the District even though it may be the low evaluated bid, or if it is so unbalanced as to be tantamount to allowing an advance payment.

RESTRICTIONS APPLICABLE TO OFFERORS: Violation of these restrictions may result in disqualification of your offer, suspension or debarment, and may constitute a violation of the state Ethics Act. (a) After issuance of the solicitation, *you agree not to discuss this procurement activity in any way with the District or its employees, agents or officials.* All communications must be solely with the Procurement Officer. This restriction may be lifted by express written permission from the Procurement Officer. This restriction expires once a contract has been formed. (b) Unless otherwise approved in writing by the Procurement Officer, *you agree not to give anything to the District or its employees, agents or officials prior to award.*

SIGNING YOUR OFFER: Every Offer must be signed by an individual with actual authority to bind the Offeror. (a) If the Offeror is an individual, the Offer must be signed by that individual. If the Offeror is an individual doing business as a firm, the Offer must be submitted in the firm name, signed by the individual, and state that the individual is doing business as a firm. (b) If the Offeror is a partnership, the Offer must be submitted in the partnership name, followed by the words "by its Partner," and signed by a general partner. (c) If the Offeror is a corporation, the Offer must be submitted in the corporate name, followed by the signature and title of the person authorized to sign. (d) An Offer may be submitted by a joint venturer involving any combination of individuals, partnerships, or corporations. If the Offeror is a joint venture, the Offer must be submitted in the name of the Joint Venture and signed by every participant in the joint venture in the manner prescribed in paragraphs (a) through (c) above for each type of participant. (e) If an Offer is signed by an agent, other than as stated in subparagraphs (a) through (d) above, the Offer must state that it has been signed by an Agent. Upon request, Offeror must provide proof of the agent's authorization to bind the principal.

DISTRICT OFFICE CLOSINGS: If an emergency or unanticipated event interrupts normal District Office processes so that offers cannot be received at the District Office for receipt of bids by the exact time specified in the solicitation, the time specified for receipt of offers will be deemed to be extended to the same time of day specified in the solicitation on the first work day on which normal District Office processes resume. In lieu of an automatic extension, an Amendment may be issued to reschedule bid opening. If the District Office is closed at the time a pre-bid or pre-proposal conference is scheduled, an Amendment will be issued to reschedule the conference.

SUBMITTING CONFIDENTIAL INFORMATION: (An overview is available at http://procurement.sc.gov/webfiles/MMO_Legal/Documents/FOIA_page.pdf) For every document Offeror submits in response to or with regard to this solicitation or request, Offeror must separately mark with the word "CONFIDENTIAL" every page, or portion thereof, that Offeror contends contains information that is exempt from public disclosure because it is either (a) a trade secret as defined in Section 30-4-40(a)(1), or (b) privileged and confidential, as that phrase is used in Section 11-35-410. For every document Offeror submits in response to or with regard to this solicitation or request, Offeror must separately mark with the words "TRADE SECRET" every page, or portion thereof, that Offeror contends contains a trade secret as that term is defined by Section 39-8-20 of the Trade Secrets Act. For every document Offeror submits in response to or with regard to this solicitation or request, Offeror must separately mark with the word "PROTECTED" every page, or portion thereof, that Offeror contends is protected by Section 11-35-1810. All markings must be conspicuous; use color, bold, underlining, or some other method in order to conspicuously distinguish the mark from the other text. Do not mark your entire response (bid, proposal, quote, etc.) as confidential, trade secret, or protected! If your response, or any part thereof, is improperly marked as confidential or trade secret or protected, the District may, in its sole discretion, determine it nonresponsive. If only portions of a page are subject to some protection, do not mark the entire page. By submitting a response to this solicitation or request, Offeror (1) agrees to the public disclosure of every page of every document regarding this solicitation or request that was submitted at any time prior to entering into a contract (including, but not limited to, documents contained in a response, documents submitted to clarify a response, and documents submitted during negotiations), unless the page is conspicuously marked "TRADE SECRET" or "CONFIDENTIAL" or "PROTECTED", (2) agrees that any information not marked, as required by these bidding instructions, as a "Trade Secret" is not a trade secret as defined by the Trade Secrets Act, and (3) agrees that, notwithstanding any claims or markings otherwise, any prices, commissions, discounts, or other financial figures used to determine the award, as well as the final contract amount, are subject to public disclosure. In determining whether to release documents, the District will detrimentally rely on Offeror's marking of documents, as required by these bidding instructions, as being either "Confidential" or "Trade Secret" or "PROTECTED". By submitting a response, Offeror agrees to defend, indemnify and hold harmless the District, its officers and employees, from every claim, demand, loss, expense, cost, damage or injury, including attorney's fees, arising out of or resulting from the District withholding information that Offeror marked as "confidential" or "trade secret" or "PROTECTED". (All references to S.C. Code of Laws.)

SUBMITTING YOUR OFFER OR MODIFICATION: (a) Offers and offer modifications shall be submitted in sealed envelopes or packages – (1) Addressed to the office specified in the Solicitation; and (2) Showing the time and date specified for opening, the solicitation number, and the name and address of the bidder. (b) If you are responding to more than one solicitation, each offer must be submitted in a different envelope or package. (c) Each Offeror must submit the number of copies indicated on the Cover Page. (d) Offerors using commercial carrier services shall ensure that the Offer is addressed and marked on the outermost envelope or wrapper as prescribed in paragraphs (a)(1) and (2) of this provision when delivered to the office specified in the Solicitation. (e) Facsimile or e-mail offers, modifications, or withdrawals, will not be considered unless authorized by the Solicitation.

TAX CREDIT FOR SUBCONTRACTING WITH MINORITY FIRMS: Pursuant to Section 12-6-3350, taxpayers, who utilize certified minority subcontractors, may take a tax credit equal to 4% of the payments they make to said subcontractors. The payments claimed must be based on work performed directly for a District contract. The credit is capped at \$25,000 per year or the total tax liability; whichever is lesser. The taxpayer is eligible to claim the credit for 6 consecutive taxable years beginning with the taxable year in which the credit is first claimed. There is no carry forward of unused credits. The credit may be claimed on Form TC-2, "Minority Business Credit." A copy of the subcontractor's certificate from the Governor's Office of Small and Minority Business (OSMBA) is to be attached to the contractor's income tax return. Taxpayers must maintain evidence of work performed for a District contract by the minority subcontractor. Questions regarding the tax credit and how to file are to be referred to: SC Department of Revenue, Research and Review, Phone: (803) 898-5786, Fax: (803) 898-5888. The subcontractor must be certified as to the criteria of a "Minority Firm" by the Governor's Office of Small and Minority Business Assistance (OSMBA). Certificates are issued to subcontractors upon successful completion of the certification process. Questions regarding subcontractor certification are to be referred to: Governor's Office of Small and Minority Business Assistance, Phone: (803) 734-0657, Fax: (803) 734-2498.

TAXPAYER IDENTIFICATION NUMBER: (a) If Offeror is owned or controlled by a common parent as defined in paragraph (b) of this provision, Offeror shall submit with its Offer the name and TIN of common parent. (b) Definitions: "Common parent," as used in this provision, means that corporate entity that owns or controls an affiliated group of corporations that files its Federal income tax returns on a consolidated basis, and of which the Offeror is a member. "Taxpayer Identification Number (TIN)," as used in this provision, means the number required by the Internal Revenue Service (IRS) to be used by the Offeror in reporting income tax and other returns. The TIN may be either a Social Security Number or an Employer Identification Number. (c) If Offeror does not have a TIN, Offeror shall indicate if either a TIN has been applied for or a TIN is not required. If a TIN is not required, indicate whether (i) Offeror is a nonresident alien, foreign corporation, or foreign partnership that does not have income effectively

connected with the conduct of a trade or business in the United States and does not have an office or place of business or a fiscal paying agent in the United States; (ii) Offeror is an agency or instrumentality of a state or local government; (iii) Offeror is an agency or instrumentality of a foreign government; or (iv) Offeror is an agency or instrumentality of the Federal Government.

VENDOR REGISTRATION: Offerors who have not provided products/services to the District in the past or within the past three years should complete a W-9 and submit it with your offer.

WITHDRAWAL OR CORRECTION OF OFFER: Offers may be withdrawn by written notice received at any time before the exact time set for opening. If the Solicitation authorizes facsimile offers, offers may be withdrawn via facsimile received at any time before the exact time set for opening. A bid may be withdrawn in person by a bidder or its authorized representative if, before the exact time set for opening, the identity of the person requesting withdrawal is established and the person signs a receipt for the bid. The withdrawal and correction of Offers is governed by Article 5 – 1520 of the District’s Procurement Code.

DISCLOSURE OF CONFLICTS OF INTEREST OR UNFAIR COMPETITIVE ADVANTAGE: You warrant and represent that your offer identifies and explains any unfair competitive advantage you may have in competing for the proposed contract and any actual or potential conflicts of interest that may arise from your participation in this competition or your receipt of an award. The two underlying principles are (a) preventing the existence of conflicting roles that might bias a contractor’s judgment, and (b) preventing an unfair competitive advantage. If you have an unfair competitive advantage or a conflict of interest, the District may withhold award. Before withholding award on these grounds, an Offeror will be notified of the concerns and provided a reasonable opportunity to respond. Efforts to avoid or mitigate such concerns, including restrictions on future activities, may be considered.

II. INSTRUCTIONS TO OFFERORS – B. SPECIAL INSTRUCTIONS

CONFERENCE – PRE-BID & Site Visit

Pre-Bid Conference Date and Time: February 7th, 2024 at 10:00 am ET

Location of Pre-Bid/Proposal Conference: River Bluff High School , 320 Corley Mill Road , Lexington, SC 29072

Due to the importance of all offerors having a clear understanding of the specifications and requirements of this solicitation, a conference of potential offerors will be held on the date specified on the cover page. **Bring a copy of the solicitation with you. Any changes resulting from this conference will be noted in a written amendment to the solicitation. Your failure to attend will not relieve the Contractor from responsibility for estimating properly the difficulty and cost of successfully performing the work, or for proceeding to successfully perform the work without additional expense to the District.** The District assumes no responsibility for any conclusions or interpretations made by the Contractor based on the information made available at the conference. Nor does the District assume responsibility for any understanding reached or representation made concerning conditions which can affect the work by any of its officers or agents before the execution of this contract, unless that understanding or representation is expressly stated in this contract.

BID SUBMITTAL: All bidding documents must be submitted in a sealed envelope. Do not include more than one bid per envelope. The face of the envelope shall contain the bid title, the bid number, and the date and time of bid opening. Bids not submitted on bid form will be subject to rejection. The district assumes no responsibility for unmarked or improperly marked envelopes.

BID BOND: Bids must be accompanied by a bid security in an amount of not less than five percent of the Base Bid. The bid security shall be a bid bond or a certified cashier's check. The Bid Bond shall: _

1. be issued by a surety company licensed to do business in South Carolina;
2. be issued by a surety company having, at minimum, a “Best Rating” of “A” as stated in the most current publication of "Best's Key Rating Guide, Property-Casualty", which company shows a financial strength rating of at least five (5) times the contract price.
3. be enclosed in the bid envelope at the time of Bid Opening.

PERFORMANCE AND PAYMENT BONDS: Payment and Performance Bonds are required and shall be in the amount of 100% of the Contract Sum.

CLARIFICATION: Pursuant to Section 11-35-1520(8), the Procurement Officer may elect to communicate with you after opening for the purpose of clarifying either your offer or the requirements of the solicitation. Such communications may be conducted only with

Offerors who have submitted an offer which obviously conforms in all material aspects to the solicitation. Clarification of an offer must be documented in writing and included with the offer. Clarifications may not be used to revise an offer or the solicitation.

BACKGROUND CHECKS: Any and all persons with whom vendor/contractor employs, contracts, or otherwise causes to be located on District property shall have passed a South Carolina and Nationwide criminal background check, to include the nationwide Sex Offender Registry. Successful completion of the criminal background checks shall occur prior to such individuals being present on District property. The contractor/vendor is solely responsible for any and all fees and/or charges associated with completion of the background check(s) required herein. The District reserves the right to deny access to any employee, contractor or person caused to be present on District property by the vendor/contractor. Removal of employees on this basis shall not disrupt the project schedule or cost.

BID AS SPECIFIED: Bid only as specified.

PROTEST: Any protest must be addressed to the Chief Procurement Officer, Lexington County School District One, and submitted in writing by e-mail or post delivery as follows:

Mailing Address: Lexington County School District One
Procurement Services, Chief Procurement Officer
Ref: Protest – Solicitation Number (as on Cover Page of this document)
100 Tarrar Springs Road
Lexington, South Carolina 29072

Email: jmiller@lexington1.net and emarsh@lexingotn1.net
Subject Line: Protest - Ref: Solicitation Number (as on Cover Page of this document)

EVERY RESULTING CONTRACT IS SUBJECT TO ALL TERMS OF THE DISTRICT PROCUREMENT CODE INCLUDING LIMITATIONS AS TO DURATION, RIGHTS OF THE DISTRICT TO TERMINATE AND MEANS OF DISPUTE RESOLUTION. NO RESULTING CONTRACT IS RENEWABLE EXCEPT TO THE EXTENT PROVIDED IN THE SOLICITATION. NO VENDOR TERMS TAKE PRECEDENCE OVER THE SOLICITATION AND DISTRICT PROCUREMENT CODE.

SITE VISIT : Non-mandatory site visit/Pre-Bid meeting will be held on 02/07/2024 10:00AM ET.

UNIT PRICES REQUIRED: Unit price to be shown for each item.

III. SCOPE OF WORK / SPECIFICATIONS

SCOPE OF WORK: Attachment A

BIDDING SCHEDULE: See Bidding Schedule – Part VIII.

DELIVERY DATE: Project completion by June 30th, 2024.

DELIVERY LOCATION: After award, all deliveries shall be made to the following locations:

River Bluff High School
320 Corley Mill Road
Lexington, SC 29072

All deliveries shall be FOB Destination. All delivery charges are to be paid by the contractor and included in the price of the goods, not invoiced separately. Any claim for loss or damages shall be between the contractor and the carrier.

QUALITY – NEW: All items must be new.

IV. INFORMATION FOR OFFERORS TO SUBMIT

INFORMATION FOR OFFERORS TO SUBMIT – GENERAL: Offeror shall submit a signed Cover Page and Page Two. Offeror should submit all other information and documents requested in this part and in parts II.B. Special Instructions; III. Scope of Work; V. Qualifications; VIII. Bidding Schedule/Price Proposal; and any appropriate attachments addressed in section IX. Attachments to Solicitations.

MINORITY PARTICIPATION: Refer to Page Two of solicitation.

SUBMITTING REDACTED OFFERS: You are required to mark the original copy of your offer to identify any information that is exempt from public disclosure. You must do so in accordance with the clause entitled "Submitting Confidential Information." In addition, you must also submit one complete copy of your offer from which you have removed any information that you marked as exempt, i.e., a redacted copy. The information redacted should mirror in every detail the information marked as exempt from public disclosure. The redacted copy should (i) reflect the same pagination as the original, (ii) show the empty space from which information was redacted, and (iii) be submitted on magnetic media. (See clause entitled "Magnetic Media Required Format.") Except for the redacted information, the CD must be identical to the original hard copy. Portable Document Format (.pdf) is preferred.

V. QUALIFICATIONS

QUALIFICATION OF OFFEROR: To be eligible for award of a contract, a prospective contractor must be responsible. In evaluating an Offeror's responsibility, the District Standards of Responsibility and information from any other source may be considered. An Offeror must, upon request of the District, furnish satisfactory evidence of its ability to meet all contractual requirements. Unreasonable failure to supply information promptly in connection with a responsibility inquiry may be grounds for determining that you are ineligible to receive an award. [Article 5 – 1810 of the District's Procurement Code]

QUALIFICATIONS - SPECIAL STANDARDS OF RESPONSIBILITY:

(a) This section establishes special standards of responsibility. **UNLESS YOU POSSESS THE FOLLOWING MANDATORY MINIMUM QUALIFICATION(S), DO NOT SUBMIT AN OFFER:**

1. The designated Supervisory Personnel on the project shall be certified, in writing by the turf manufacturer, as competent in the installation of specified slitfilm/monofilament material, including sewing seams and proper installation of the infill mixture.
2. Installer shall be certified by the manufacturer and licensed.
3. The installer supervisor shall have a minimum of 5 years experience as either a construction manager or a supervisor of synthetic turf installations
4. Project must be completion by June 30th, 2024

(b) **Provide a detailed, narrative statement with adequate information to establish that you meet all the requirements stated in subparagraph (a)(1) above.** Include all appropriate documentation. If you intend for us to consider the qualifications of your key personnel, predecessor business(es), or subcontractor(s), explain the relationship between you and such person or entity.

DISTRICT STANDARDS OF RESPONSIBILITY: Factors to be considered in determining whether the District standards of responsibility have been met include whether a prospective contractor has:

- available the appropriate financial, material, equipment, facility, and personnel resources and expertise, or the ability to obtain them, necessary to indicate its capability to meet all contractual requirements;
- a satisfactory record of performance;

- a satisfactory record of integrity;
- qualified legally to contract with the District and State; and
- supplied all necessary information in connection with the inquiry concerning responsibility.

14

VI. AWARD CRITERIA

AWARD CRITERIA – BIDS: Award will be made to the lowest responsible and responsive bidder.

AWARD TO ONE OFFEROR: Award will be made to one Offeror.

CALCULATING THE LOW BID: The Low Bid is that bid with the lowest Total Bid. The Total Bid amount is the sum of the Extended Prices in the Bidding Schedule. The Extended Price is calculated by adding the base bid plus accepted alternate bids.

UNIT PRICE GOVERNS: In determining award, unit prices will govern over extended prices unless otherwise stated.

15

VII. TERMS AND CONDITIONS – A. GENERAL

ASSIGNMENT, NOVATION, AND CHANGE OF NAME, IDENTITY, OR STRUCTURE (FEB 2015): (a) Contractor shall not assign this contract, or its rights, obligations, or any other interest arising from this contract, or delegate any of its performance obligations, without the express written consent of the responsible procurement officer. The foregoing restriction does not apply to a transfer that occurs by operation of law (e.g., bankruptcy; corporate reorganizations and consolidations, but not including partial asset sales). Notwithstanding the foregoing, contractor may assign monies receivable under the contract provided that the state shall have no obligation to make payment to an assignee until thirty days after contractor (not the assignee) has provided the responsible procurement officer with (i) proof of the assignment, (ii) the identity (by contract number) of the specific state contract to which the assignment applies, and (iii) the name of the assignee and the exact address or account information to which assigned payments should be made. (b) If contractor amends, modifies, or otherwise changes its name, its identity (including its trade name), or its corporate, partnership or other structure, or its FEIN, contractor shall provide the procurement officer prompt written notice of such change. (c) Any name change, transfer, assignment, or novation is subject to the review and approval of the Procurement Officer.

AFFIRMATIVE ACTION: The successful bidder will take affirmative action in complying with all federal and state requirements concerning fair employment and employment of the handicapped, and concerning the treatment of all employees, without regard or discrimination by reason of race, color, religion, sex, national origin or physical handicap. The following are incorporated herein by reference: 41 C.F.R. 60-1.4, 60-250.4 and 60-741.4.

BANKRUPTCY: (a) Notice. In the event the Contractor enters into proceedings relating to bankruptcy, whether voluntary or involuntary, the Contractor agrees to furnish written notification of the bankruptcy to the District. This notification shall be furnished within five (5) days of the initiation of the proceedings relating to the bankruptcy filing. This notification shall include the date on which the bankruptcy petition was filed, the identity of the court in which the bankruptcy petition was filed, and a listing of all District contracts against which final payment has not been made. This obligation remains in effect until final payment under this Contract. (b) Termination. This contract is voidable and subject to immediate termination by the District upon the contractor's insolvency, including the filing of proceedings in bankruptcy.

CHOICE-OF-LAW: The Agreement, any dispute, claim, or controversy relating to the Agreement, and all the rights and obligations of the parties shall, in all respects, be interpreted, construed, enforced and governed by and under the laws of the State of South Carolina, except its choice of law rules. As used in this paragraph, the term "Agreement" means any transaction or agreement arising out of, relating to, or contemplated by the solicitation.

CONTRACT DOCUMENTS & ORDER OF PRECEDENCE: (a) Any contract resulting from this solicitation shall consist of the following documents: (1) a Record of Negotiations, if any, executed by you and the Procurement Officer, (2) the solicitation, as amended, (3) modifications, if any, to your offer, if accepted by the Procurement Officer, (4) your offer, (5) any statement reflecting the District's final acceptance (a/k/a "award"), and (6) purchase orders. These documents shall be read to be consistent and complementary. Any conflict among these documents shall be resolved by giving priority to these documents in the order listed above. (b) The terms and conditions of documents (1) through (5) above shall apply notwithstanding any additional or different terms and conditions in either (i) a purchase order or other instrument submitted by the District or (ii) any invoice or other document submitted by Contractor. Except as otherwise allowed herein, the terms and conditions of all such documents shall be void and of no

effect. (c) No contract, license, or other agreement containing contractual terms and conditions will be signed by the District. Any document signed or otherwise agreed to by persons other than the Procurement Officer shall be void and of no effect.

DISCOUNT FOR PROMPT PAYMENT:

(a) Discounts for prompt payment will not be considered in the evaluation of offers. However, any offered discount will form a part of the award, and will be taken if payment is made within the discount period indicated in the offer by the Offeror. As an alternative to offering a discount for prompt payment in conjunction with the offer, Offerors awarded contracts may include discounts for prompt payment on individual invoices.

(b) In connection with any discount offered for prompt payment, time shall be computed from the date of the invoice. If the Contractor has not placed a date on the invoice, the due date shall be calculated from the date the designated billing office receives a proper invoice, provided the state annotates such invoice with the date of receipt at the time of receipt. For the purpose of computing the discount earned, payment shall be considered to have been made on the date that appears on the payment check or, for an electronic funds transfer, the specified payment date. When the discount date falls on a Saturday, Sunday, or legal holiday when Federal Government offices are closed and Government business is not expected to be conducted, payment may be made on the following business day.

DISPUTES: (1) Choice-of-Forum. All disputes, claims, or controversies relating to the Agreement shall be resolved exclusively by the appropriate Chief Procurement Officer in accordance with the District's Procurement Code. As used in this paragraph, the term "Agreement" means any transaction or agreement arising out of, relating to, or contemplated by the solicitation. (2) Service of Process. Contractor consents that any papers, notices, or process necessary or proper for the initiation or continuation of any disputes, claims, or controversies relating to the Agreement; for any court action in connection therewith; or for the entry of judgment on any award made, may be served on Contractor by certified mail (return receipt requested) addressed to Contractor at the address provided as the Notice Address on Page Two or by personal service or by any other manner that is permitted by law, in or outside South Carolina. Notice by certified mail is deemed duly given upon deposit in the United States mail.

EQUAL OPPORTUNITY: Contractor is referred to and shall comply with all applicable provisions, if any, of Title 41, Part 60 of the Code of Federal Regulations, including but not limited to Sections 60-1.4, 60-4.2, 60-4.3, 60-250.5(a), and 60-741.5(a), which are hereby incorporated by reference.

FALSE CLAIMS: According to the S.C. Code of Laws § 16-13-240, "a person who by false pretense or representation obtains the signature of a person to a written instrument or obtains from another person any chattel, money, valuable security, or other property, real or personal, with intent to cheat and defraud a person of that property is guilty" of a crime.

FIXED PRICING REQUIRED: Any pricing provided by the contractor shall include all costs for performing the work associated with that price. Contractor's price shall be fixed for the duration of each term. This clause does not prohibit contractors from offering lower pricing after award.

ITEM SUBSTITUTION: (This clause does not apply to solicitations for service requirements). No substitutes will be allowed on purchase orders received from the District without permission from the Procurement Official.

NO INDEMNITY OR DEFENSE: Any term or condition is void to the extent it requires the District to indemnify, defend, or pay attorney's fees to anyone for any reason.

NOTICE: (a) After award, any notices shall be in writing and shall be deemed duly given (1) upon actual delivery, if delivery is by hand, (2) upon receipt by the transmitting party of automated confirmation or answer back from the recipient's device if delivery is by telex, telegram, facsimile, or electronic mail, or (3) upon deposit into the United States mail, if postage is prepaid, a return receipt is requested, and either registered or certified mail is used. (b) Notice to contractor shall be to the address identified as the Notice Address on Page Two. Notice to the District shall be to the Procurement Officer's address on the Cover Page. Either party may designate a different address for notice by giving notice in accordance with this paragraph.

OPEN TRADE: During the contract term, including any renewals or extensions, Contractor will not engage in the boycott of a person or an entity based in or doing business with a jurisdiction with whom South Carolina can enjoy open trade, as defined in SC Code Section 11-35-5300.

PAYMENT & INTEREST: (a) Unless otherwise provided in this Solicitation, the District shall pay the Contractor, after the submission of proper invoices or vouchers, the prices stipulated in this contract for supplies delivered and accepted or services rendered and accepted, less any deductions provided in this contract. Unless otherwise specified herein, including the purchase

order, payment shall not be made on partial deliveries accepted by the District. (b) Unless otherwise provided herein, including the purchase order, payment will be made by check. (c) Notwithstanding any other provision, payment shall be made in accordance with the District's Procurement Code Section 45, which provides the Contractor's exclusive means of recovering any type of interest from the Owner. Contractor waives imposition of an interest penalty unless the invoice submitted specifies that the late penalty is applicable. Except as set forth in this paragraph, the District shall not be liable for the payment of interest on any debt or claim arising out of or related to this contract for any reason. (d) Amounts due to the District shall bear interest at the rate of interest established by the South Carolina Comptroller General pursuant to Section 45 ("an amount not to exceed fifteen percent each year"), as amended. (e) Any other basis for interest, including but not limited to general (pre- and post-judgment) or specific interest statutes, including S.C. Code Ann. § 34-31-20, are expressly waived by both parties. If a court, despite this agreement and waiver, requires that interest be paid on any debt by either party other than as provided by items (c) and (d) above, the parties further agree that the applicable interest rate for any given calendar year shall be the lowest prime rate as listed in the first edition of the Wall Street Journal published for each year, applied as simple interest without compounding.

PUBLICITY: Contractor shall not publish any comments or quotes by District employees, or include the District in either news releases or a published list of customers, without the prior written approval of the Procurement Officer.

PURCHASE ORDERS: Contractor shall not perform any work prior to the receipt of a purchase order from the District. The District shall order any supplies or services to be furnished under this contract by issuing a purchase order. Purchase orders may be used to elect any options available under this contract, e.g., quantity, item, delivery date, payment method, but are subject to all terms and conditions of this contract.

SURVIVAL OF OBLIGATIONS: The Parties' rights and obligations which, by their nature, would continue beyond the termination, cancellation, rejection, or expiration of this contract shall survive such termination, cancellation, rejection, or expiration, including, but not limited to, the rights and obligations created by the following clauses: Indemnification - Third Party Claims, Intellectual Property Indemnification, and any provisions regarding warranty or audit.

SWMBE PARTICIPATION: Lexington County School District One encourages SWMBE businesses to participate in the Solicitation process. All business conducted with SWMBE businesses certified by the South Carolina Governor's Office of Small and Minority Business Assistance is recorded in an annual report submitted to the Board of Trustees. In order to be included in this report, you must submit a copy of your certificate with your bid.

TAXES: Any tax the contractor may be required to collect or pay upon the sale, use or delivery of the products shall be paid by the District, and such sums shall be due and payable to the contractor upon acceptance. Any personal property taxes levied after delivery shall be paid by the District. It shall be solely the District's obligation, after payment to contractor, to challenge the applicability of any tax by negotiation with, or action against, the taxing authority. Contractor agrees to refund any tax collected, which is subsequently determined not to be proper and for which a refund has been paid to contractor by the taxing authority. In the event that the contractor fails to pay, or delays in paying, to any taxing authorities, sums paid by the District to contractor, contractor shall be liable to the District for any loss (such as the assessment of additional interest) caused by virtue of this failure or delay. Taxes based on Contractor's net income or assets shall be the sole responsibility of the contractor.

TERMINATION: Subject to the conditions below, the District, providing a (30) thirty-day advance written notice is given to the vendor, may terminate the contract for any reason.

NON-APPROPRIATIONS: Any contract entered into by the District resulting from this bid invitation shall be subject to cancellation without damages or further obligation when funds are not appropriated or otherwise made available to support continuation of performance in a subsequent fiscal period or appropriated year.

FOR CONVENIENCE: In the event that this contract is terminated or canceled upon request and for the convenience of the District without the required thirty (30) days advance written notice, then the District may negotiate reasonable termination costs, if applicable.

FOR CAUSE: Termination by the District for cause, default or negligence on the part of the vendor shall be excluded from the foregoing conditions; termination costs, if any, shall not apply. The thirty (30) days advance notice requirement is waived and the default clause in this bid shall apply.

DEFAULT: In case of default by the vendor, the District reserves the right to purchase any or all items in default in the open market, charging the vendor with any additional costs. The defaulting vendor shall not be considered a responsible bidder until the assessed charge has been satisfied. **TERMINATION DUE TO**

TERMINATION DUE TO UNAVAILABILITY OF FUNDS: Payment and performance obligations for succeeding fiscal periods shall be subject to the availability and appropriation of funds therefor. When funds are not appropriated or otherwise made available to

support continuation of performance in a subsequent fiscal period, the contract shall be canceled. In the event of a cancellation pursuant to this paragraph, contractor will be reimbursed the resulting unamortized, reasonably incurred, nonrecurring costs. Contractor will not be reimbursed any costs amortized beyond the initial contract term.

THIRD PARTY BENEFICIARY: This Contract is made solely and specifically among and for the benefit of the parties hereto, and their respective successors and assigns, and no other person will have any rights, interest, or claims hereunder or be entitled to any benefits under or on account of this Contract as a third party beneficiary or otherwise.

WAIVER: The District does not waive any prior or subsequent breach of the terms of the Contract by making payments on the Contract, by failing to terminate the Contract for lack of performance, or by failing to strictly or promptly insist upon any term of the Contract. Only the Procurement Officer has actual authority to waive any of the District's rights under this Contract. Any waiver must be in writing.

ILLEGAL IMMIGRATION: (An overview is available at www.procurement.sc.gov)

By signing your offer, you certify that you will comply with the applicable requirements of Title 8, Chapter 14 of the South Carolina Code of Laws and agree to provide to the State upon request any documentation required to establish either: (a) that Title 8, Chapter 14 is inapplicable to you and your subcontractors or sub-subcontractors; or (b) that you and your subcontractors or sub-subcontractors are in compliance with Title 8, Chapter 14. Pursuant to Section 8-14-60, "A person who knowingly makes or files any false, fictitious, or fraudulent document, statement, or report pursuant to this chapter is guilty of a felony, and, upon conviction, must be fined within the discretion of the court or imprisoned for not more than five years, or both." You agree to include in any contracts with your subcontractors language requiring your subcontractors to (a) comply with the applicable requirements of Title 8, Chapter 14, and (b) include in their contracts with the sub-subcontractors language requiring the sub-subcontractors to comply with the applicable requirements of Title 8, Chapter 14.

18

VII. TERMS AND CONDITIONS – B. SPECIAL

1. Time of Substantial Completion: Unless an extension of time is granted, work under this contract shall be substantially complete on June 30th, 2024. Substantial completion is defined as the date all work is certified by the District and Third-Party Inspector as being sufficiently complete in accordance with the contract documents, so that people may safely occupy the workspace for use of which it was intended.
2. Time of Final Completion: Unless an extension is granted, work under this contract shall be finally complete upon the EOR and 3rd party final inspection.
3. Liquidated Damages: Should the contractor fail to substantially complete the work under this contract within the stipulated days plus any additional that may result from extensions of time granted by the owner, the contractor agrees that the Owner may retain the sum of:

Liquidated Damages will be assessed in the amount of \$250.00 for each calendar day the actual Contract Time for Substantial Completion exceeds the specified Date of Substantial Completion.

CHANGES:

(1) Contract Modification. By a written order, at any time, and without notice to any surety, the Procurement Officer may, subject to all appropriate adjustments, make changes within the general scope of this contract in any one or more of the following: (a) drawings, designs, or specifications, if the supplies to be furnished are to be specially manufactured for the [District] in accordance therewith;

(b) method of shipment or packing;

(c) place of delivery;

(d) description of services to be performed;

(e) time of performance (i.e., hours of the day, days of the week, etc.); or,

(f) place of performance of the services.

Subparagraphs (a) to (c) apply only if supplies are furnished under this contract. Subparagraphs (d) to (f) apply only if services are performed under this contract.

(2) Adjustments of Price or Time for Performance. If any such change increases or decreases the contractor's cost of, or the time required for, performance of any part of the work under this contract, whether or not changed by the order, an adjustment shall be made in the contract price, the delivery schedule, or both, and the contract modified in writing accordingly. Any adjustment in contract price made pursuant to this clause shall be determined in accordance with the Price Adjustment Clause of this contract. Failure of the parties to agree to an adjustment shall not excuse the contractor from proceeding with the contract as changed,

provided that the District promptly and duly make such provisional adjustments in payment or time for performance as may be reasonable. By proceeding with the work, the contractor shall not be deemed to have prejudiced any claim for additional compensation, or an extension of time for completion.

(3) **Time Period for Claim.** Within 30 days after receipt of a written contract modification under Paragraph (1) of this clause, unless such period is extended by the Procurement Officer in writing, the contractor shall file notice of intent to assert a claim for an adjustment. Later notification shall not bar the contractor's claim unless the District is prejudiced by the delay in notification. (4) **Claim Barred After Final Payment.** No claim by the contractor for an adjustment hereunder shall be allowed if notice is not given prior to final payment under this contract.

CISG: The parties expressly agree that the UN Convention on the International Sale of Goods shall not apply to this agreement.

COMPLIANCE WITH LAWS: During the term of the contract, the contractor shall comply with all applicable provisions of laws, codes, ordinances, rules, regulations, and tariffs.

CONTRACTS: Every resulting contract is subject to all terms of the district procurement code including limitations as to duration, rights of the district to terminate and means of dispute resolution. No resulting contract is renewable except to the extent provided in the solicitation. No vendor terms take precedence over the solicitation and the District's procurement code.

CONTRACTOR'S LIABILITY INSURANCE – GENERAL: (a) Without limiting any of the obligations or liabilities of Contractor, Contractor shall procure from a company or companies lawfully authorized to do business in South Carolina and with a current A.M. Best rating of no less than A: VII, and maintain for the duration of the contract, insurance against claims for injuries to persons or damages to property which may arise from or in connection with the performance of the work and the results of that work by the contractor, his agents, representatives, employees or subcontractors.

(b) Coverage shall be at least as broad as:

(1) Commercial General Liability (CGL): Insurance Services Office (ISO) Form CG 00 01 12 07 covering CGL on an "occurrence" basis, including products-completed operations, personal and advertising injury, with limits no less than \$1,000,000 per occurrence. If a general aggregate limit applies, the general aggregate limit shall be twice the required occurrence limit. This contract shall be considered to be an "insured contract" as defined in the policy.

(2) Auto Liability: ISO Form Number CA 00 01 covering any auto (Code 1), or if Contractor has no owned autos, hired, (Code 8) and non-owned autos (Code 9), with limits no less than \$1,000,000 per accident for bodily injury and property damage.

(3) Worker's Compensation: As required by the State of South Carolina, with Statutory Limits, and Employer's Liability Insurance with a limit of no less than \$1,000,000 per accident for bodily injury or disease. (c) The District and the officers, officials, employees and volunteers of any of them, must be covered as additional insureds on the CGL policy with respect to liability arising out of work or operations performed by or on behalf of the Contractor including materials, parts or equipment furnished in connection with such work or operations. General liability coverage can be provided in the form of an endorsement to the Contractor's insurance at least as broad as ISO Form CG 20 10 11 85 or if not available, through the addition of both CG 20 10 and CG 20 37 if a later edition is used. (d) For any claims related to this contract, the Contractor's insurance coverage shall be primary insurance as respects the District, and the officers, officials, employees and volunteers of any of them. Any insurance or self-insurance maintained by the District or the officers, officials, employees and volunteers of any of them, shall be excess of the Contractor's insurance and shall not contribute with it.

(e) Prior to commencement of the work, the Contractor shall furnish the District with original certificates and amendatory endorsements or copies of the applicable policy language effecting coverage required by this section. All certificates are to be received and approved by the District before work commences. However, failure to obtain the required documents prior to the work beginning shall not waive the Contractor's obligation to provide them. The District reserves the right to require complete, certified copies of all required insurance policies, including endorsements required by this section, at any time.

f) Should any of the above described policies be canceled before the expiration date thereof, notice will be delivered in accordance with the policy provisions. In addition, the Contractor shall notify the District immediately upon receiving any information that any of the coverages required by this section are or will be changed, canceled, or replaced. (g) Contractor hereby grants to the District a waiver of any right to subrogation which any insurer of said Contractor may acquire against the District by virtue of the payment of any loss under such insurance. Contractor agrees to obtain any endorsement that may be necessary to effect this waiver of subrogation, but this provision applies regardless of whether or not the District has received a waiver of subrogation endorsement from the insurer. (h) Any deductibles or self-insured retentions must be declared to and approved by the District. The District may require the Contractor to purchase coverage with a lower deductible or retention or provide proof of ability to pay losses and related investigations, claim administration, and defense expenses within the retention.

(i) The District reserves the right to modify these requirements, including limits, based on the nature of the risk, prior experience, insurer, coverage, or other special circumstances.

CONTRACTOR PERSONNEL: The Contractor shall enforce strict discipline and good order among the Contractor's employees and other persons carrying out the Contract. The Contractor shall not permit employment of unfit persons or persons not skilled in tasks assigned to them. No forms of tobacco products, alcohol, and drugs are allowed on the District's premises.

CONTRACTOR'S OBLIGATION – GENERAL: The contractor shall provide and pay for all materials, tools, equipment, labor and professional and non-professional services, and shall perform all other acts and supply all other things necessary, to fully and properly perform and complete the work. The contractor must act as the prime contractor and assume full responsibility for any subcontractor's performance. The contractor will be considered the sole point of contact with regard to all situations, including payment of all charges and the meeting of all other requirements.

CONTRACTOR'S USE OF DISTRICT PROPERTY: Upon termination of the contract for any reason, the District shall have the right, upon demand, to obtain access to, and possession of, all District properties, including, but not limited to, current copies of all District application programs and necessary documentation, all data, files, intermediate materials and supplies held by the contractor. Contractor shall not use, reproduce, distribute, display, or sell any data, material, or documentation owned exclusively by the District without the District's written consent, except to the extent necessary to carry out the work.

DEFAULT:

(a)(1) The District may, subject to paragraphs (c) and (d) of this clause, by written notice of default to the Contractor, terminate this contract in whole or in part if the Contractor fails to-

(i) Deliver the supplies or to perform the services within the time specified in this contract or any extension; (ii) Make progress, so as to endanger performance of this contract (but see paragraph (a)(2) of this clause); or (iii) Perform any of the other material provisions of this contract (but see paragraph (a)(2) of this clause). (2) The District's right to terminate this contract under subdivisions (a)(1)(ii) and (1)(iii) of this clause, may be exercised if the Contractor does not cure such failure within 10 days (or more if authorized in writing by the Procurement Officer) after receipt of the notice from the Procurement Officer specifying the failure.

(b) If the District terminates this contract in whole or in part, it may acquire, under the terms and in the manner the Procurement Officer considers appropriate, supplies or services similar to those terminated, and the Contractor will be liable to the District for any excess costs for those supplies or services. However, the Contractor shall continue the work not terminated. (c) Except for defaults of subcontractors at any tier, the Contractor shall not be liable for any excess costs if the failure to perform the contract arises from causes beyond the control and without the fault or negligence of the Contractor. Examples of such causes include (1) acts of God or of the public enemy, (2) acts of the District in either its sovereign or contractual capacity, (3) fires, (4) floods, (5) epidemics, (6) quarantine restrictions, (7) strikes, (8) freight embargoes, and (9) unusually severe weather. In each instance the failure to perform must be beyond the control and without the fault or negligence of the Contractor. (d) If the failure to perform is caused by the default of a subcontractor at any tier, and if the cause of the default is beyond the control of both the Contractor and subcontractor, and without the fault or negligence of either, the Contractor shall not be liable for any excess costs for failure to perform, unless the subcontracted supplies or services were obtainable from other sources in sufficient time for the Contractor to meet the required delivery schedule.

(e) If this contract is terminated for default, the District may require the Contractor to transfer title and deliver to the District, as directed by the Procurement Officer, any (1) completed supplies, and (2) partially completed supplies and materials, parts, tools, dies, jigs, fixtures, plans, drawings, information, and contract rights (collectively referred to as "manufacturing materials" in this clause) that the Contractor has specifically produced or acquired for the terminated portion of this contract. Upon direction of the Procurement Officer, the Contractor shall also protect and preserve property in its possession in which the District has an interest.

(f) The District shall pay contract price for completed supplies delivered and accepted. The Contractor and Procurement Officer shall agree on the amount of payment for manufacturing materials delivered and accepted and for the protection and preservation of the property; if the parties fail to agree, the Procurement Officer shall set an amount subject to the Contractor's rights under the Disputes clause. Failure to agree will be a dispute under the Disputes clause. The District may withhold from these amounts any sum the Procurement Officer determines to be necessary to protect the District against loss because of outstanding liens or claims of former lien holders.

(g) If, after termination, it is determined that the Contractor was not in default, or that the default was excusable, the rights and obligations of the parties shall, if the contract contains a clause providing for termination for convenience of the District, be the same as if the termination had been issued for the convenience of the District. If, in the foregoing circumstances, this contract does not contain a clause providing for termination for convenience of the District, the contract shall be adjusted to compensate for such termination and the contract modified accordingly subject to the contractor's rights under the Disputes clause.

(h) The rights and remedies of the District in this clause are in addition to any other rights and remedies provided by law or under this contract.

DEFECTIVE GOODS: Any item delivered in an unacceptable condition will not be accepted. Successful bidder agrees to pay for the return shipment of goods that arrive in a defective or inoperable condition. The Offeror must agree to arrange for the return shipment of damaged goods.

DESCRIPTIVE LITERATURE – LABELING: Include offeror’s name on the cover of any specifications or descriptive literature submitted with your offer.

INDEMNIFICATION - THIRD PARTY CLAIMS: Notwithstanding any limitation in this agreement, and to the fullest extent permitted by law, Contractor shall defend and hold harmless Indemnitees for and against any and all suits or claims of any character (and all related damages, settlement payments, attorneys' fees, costs, expenses, losses or liabilities) by a third party which are attributable to bodily injury, sickness, disease or death, or to injury to or destruction of tangible property arising out of or in connection with the goods or services acquired hereunder or caused in whole or in part by any act or omission of contractor, its subcontractors, their employees, workmen, servants, agents, or anyone directly or indirectly employed by them or anyone for whose acts any of them may be liable, regardless of whether or not caused in part by an Indemnitee, and whether or not such claims are made by a third party or an Indemnitee; however, if an Indemnitee’s negligent act or omission is subsequently determined to be the sole proximate cause of a suit or claim, the Indemnitee shall not be entitled to indemnification hereunder. Contractor shall be given timely written notice of any suit or claim. Contractor’s obligations hereunder are in no way limited by any protection afforded under workers compensation acts, disability benefits acts, or other employee benefit acts. This clause shall not negate, abridge, or reduce any other rights or obligations of indemnity which would otherwise exist. The obligations of this paragraph shall survive termination, cancelation, or expiration of the parties' agreement. This provision shall be construed fairly and reasonably, neither strongly for nor against either party, and without regard to any clause regarding insurance. As used in this clause, Indemnitees means the State of South Carolina, its instrumentalities, agencies, departments, boards, political subdivisions and all their respective officers, agents and employees.

DISTRICT SITE ACCESS – Contractor’s personnel must wear an identification badge as approved by the District and shall utilize the procedures authorized by the District to obtain access to District buildings. The District requires Contractor’s personnel to enter through the front office.

District sites have a comprehensive visitor check-in and check-out software system located at the front desk. This system runs a background check on each visitor every time he or she visits. Each visitor must check in and out when in a school or on school grounds, regardless of the time of day. Should the system flag an individual for *any* reason, the system will automatically and privately alert the front office staff and the school’s administrators. Those administrators will then talk to the individual and work through any issue. For additional information in regard to the procedures go to web site: <http://www.lexington1.net/?page=NEWS/Issues/SchoolCheckIN/schoolcheckIN.htm>

NOTE: Contractor’s personnel are not required to check-in at the front desk when performing the normal pick up service. Contractor’s personnel are required to have personal identification and company credentials when on school property and shall produce when requested by school personnel. If, for any reason, Contractor’s personnel are entering the school building(s), or are engaged in any activity other than regular service, the following procedures shall be followed: Contractor personnel are required to check in at the front office/desk with personal identification and company credentials, and will be issued a name tag before accessing any District property.

TOBACCO FREE ENVIRONMENT – The District provides a smoke and tobacco free environment for its staff, students and the general public. No tobacco products are permitted in any building or on the grounds of any District building.

CONTRACTOR’S CARE – Contractor shall exercise due care in protecting all property and surrounding property. Contractor will be responsible for any damage and will be required to restore any damage. If the contractor fails or refuses to repair any damage promptly, the District may have the necessary work performed and charge the pricing thereof to the contractor.

VIII. BIDDING SCHEDULE

Vendor Name _____

Provide all labor, equipment, transportation, materials and supplies necessary to perform the work as specified in this solicitation.

LINE ITEM	DESCRIPTION/PART NUMBER	Total
BASE BID	INSTALLATION OF NEW 2.5" SAND/RUBBER TURF SYSTEM PER SPECIFICATIONS AND NEW TEN (10) TREATED WOOD STORM BOX ACCESS PANELS. BASE BID INCLUDES FIELD GRAPHICS, GMAX TEST AT COMPLETION, 8-YR WARRANTY, FIELD REMOVAL AND LASER GRADING OF EXISTING BASE.	\$
	NAILER BOARD REPLACEMENT. PROVIDE COST TO REMOVE EXISTING DAMAGED NAILER BOARD, DISPOSE OF OFF-SITE AND INSTALL NEW TREATED LUMBER NAILER, PER LINEAR FOOT	\$ _____/LF

	DESCRIPTION/PART NUMBER	Total
Alternate No. 1	PROVIDE PULL BEHIND DRAG EQUIPMENT FIELD GROOMER AND SWEEPER TO CLEAN SYNTHETIC TURF SURFACE	\$
Alternate No. 2	WARRANTY EXTENSION FROM 8 YEARS TO 10 YEARS	\$
Alternate No. 2	ADD 2.5" FIELDTURF VERTEX CORE WITH COOLING COMPOSITE PER SPECIFICATIONS	\$

Signature of Authorized Official: _____

Print name and Title: _____

IX. ATTACHMENTS TO SOLICITATION

- A. Scope of Work/Specifications
- B. Architectural Drawings
- C. Minority Participation Affidavit
- D. Offeror's Checklist

ATTACHMENT A
SCOPE OF WORK

SECTION 32 1000 – AGGREGATE BASE COURSE

PART 1 - GENERAL

1.1 RELATED DOCUMENTS

A. Drawings and general provisions of the Contract, including General and Supplementary Conditions and Division 1 Specification Sections, apply to this Section.

1.2 SECTION INCLUDES

- A. Aggregate Base Course under Slabs-on-Grade.
- B. Aggregate Base Course under Sidewalks and Pads.
- C. Aggregate Base Course under Roads and Parking Areas.

1.3 RELATED SECTIONS

- A. Section 31 2000 – Earth Moving.
- B. Section 31 2333 – Trenching and Backfilling for Site Utilities.
- C. Section 31 2500 – Erosion / Sedimentation Control.
- D. Section 32 1216 – Hot-Mix Asphalt Concrete Pavement.
- E. Section 32 1300 – Portland Cement Concrete Paving.

1.4 REFERENCES

- A. SCDOT – South Carolina State Highway Department Standard Specifications for Highway Construction, 2000 Edition.
- B. AASHTO M 147 – Standard Specification for Materials for Aggregate and Soil-Aggregate Subbase, Base and Surface Courses; American Association of State Highway and Transportation Officials; 1965 (1996).
- C. AASHTO T 180 – Standard Specification for Moisture-Density Relations of Soils Using a 4.54 kg (10 lbs) Rammer and a 457 mm (18 in.) Drop; American Association of State Highway and Transportation Officials; 1997.
- D. ASTM C136 – Standard Test Method for Sieve Analysis of Fine and Course Aggregates; 1996a.
- E. ASTM D698 – Test Method for Laboratory Compaction Characteristics of Soil Using Standard Effort (12,400 ft-lbs/ft³); 1991 (Re-Approved 1998).
- F. ASTM D1556 – Standard Test Method for Density and Unit Weight of Soil in-Place by the SandCone Method; 1990 (Re-Approved 1996).
- G. ASTM D1557 – Test Method for Laboratory Compaction Characteristics of Soil Using Modified Effort (56,000 ft-lbs/ft³); 1991 (Re-Approved 1998).
- H. ASTM D2167 – Standard Test Method for Density and Unit Weight of Soil in-Place by the Rubber Balloon Method; 1994.
- I. ASTM D2487 – Standard Classification of Soils for Engineering Purposes (Unified Soil Classification System); 1998.
- J. ASTM D2922 - Standard Test Method for Density and Unit Weight of Soil in-Place by Nuclear Methods (Shallow Depth); 1994.
- K. ASTM D3017 – Standard Test Method for Water Content of Soil and Rock in Place by Nuclear Methods (Shallow Depth); 1996.
- L. ASTM D4318 – Standard Test Method for Liquid Limit, Plastic Limit, and Plasticity Index of Soils; 1998.

1.5 DEFINITIONS

- A. Base Course: Layer placed between the subbase course and asphalt paving.
- B. Drainage Course: Layer supporting slab-on-grade used to minimize capillary flow of pore water.

- C. Structures: Buildings, footings, foundations, retaining walls, slabs, tanks, curbs, mechanical and electrical appurtenances, or other man-made stationary features constructed above or below the ground surface.
- D. Subbase Course: Layer placed between the subgrade and base course for asphalt paving, or layer placed between the subgrade and a concrete pavement or walk.
- E. Subgrade: Surface or elevation remaining after completing excavation, or top surface of a fill or backfill immediately below subbase, drainage fill, or topsoil materials.

1.6 QUALITY ASSURANCE

- A. Codes and Standards: Perform excavation work in compliance with applicable requirements of authorities having jurisdiction.
- B. Perform Work in accordance with State of South Carolina Highway Department Standard Specifications.
 - 1. Maintain one copy on site.
- C. Use adequate numbers of skilled workmen who are thoroughly trained and experienced in the necessary crafts and who are completely familiar with the specified requirements and the methods needed for proper performance of the Work of this Section.
- D. Geotechnical Testing and Inspection Service: The Owner will employ and pay for a qualified independent Geotechnical Testing Agency to perform soil testing and inspection services during earthwork operations. The Contractor shall schedule his work in such a manner to permit a reasonable amount of time for testing to be performed before placing succeeding lifts of fill material and shall keep the Testing Agency informed of all progress.
 - 1. The Owner shall pay for the cost of initial testing, subsequent tests, which are required as a result of a test failure, shall be paid for by the Contractor.
- E. Geotechnical Testing Agency Qualifications: An independent testing agency qualified according to ASTM E329 to conduct soil materials and rock-definition testing, as documented according to ASTM D3740 and ASTM E548.
- F. Use of Explosives: Use of explosives is NOT permitted on the Owner's property.
- G. Pre-Excavation Conference: Conduct conference at Project site to comply with requirements in Division 1 Specification Sections.

1.7 PROJECT CONDITIONS

- A. Provide sufficient quantities of aggregate to meet project schedule and requirements. When necessary, store materials on-site in advance of need.
- B. When aggregate materials need to be stored on-site, locate stockpiles as directed by the Owner and or Construction Manager.
 - 1. Separate differing materials with dividers or stockpile separately to prevent intermixing.
 - 2. Prevent contamination.
 - 3. Protect stockpiles from erosion and deterioration of materials.
- C. Verify that survey benchmarks and intended elevations of Work are as indicated.

PART 2 - PRODUCTS

2.1 MATERIALS

- A. Use locally available materials and gradations which exhibit a satisfactory record of previous installations.
- B. Subbase: Naturally or artificially graded mixture of natural or crushed gravel, crushed stone, and natural or crushed sand; ASTM D2940; with at least 90-percent passing a 1-1/2-inch sieve and not more than 12-percent passing a No. 200 sieve.
- C. Base: Naturally or artificially graded mixture of natural or crushed gravel, crushed stone, and natural or crushed sand;

ASTM D2940; with at least 95-percent passing a 1-1/2-inch sieve and not more than 8-percent passing a No. 200 sieve.

D. Drainage Fill: Washed, narrowly graded mixture of crushed stone, or crushed or uncrushed gravel; ASTM D448; coarse-aggregate grading Size 57; with 100-percent passing a 1-1/2- inch sieve and 0 to 5-percent passing a No. 8 sieve.

E. Filter Material: Narrowly graded mixture of natural or crushed gravel, or crushed stone and natural sand; ASTM D448; coarse-aggregate grading Size 67; with 100-percent passing a 1-inch sieve and 0 to 5-percent passing a No. 4 sieve.

F. Course Aggregate Base for Slabs-on-Grade: Drainage Course – Gravel:

1. Pit Run or Angular Crushed or Natural, washed Stone; free of shale, clay, friable material and debris.

a. Graded in accordance with ASTM D2487 Group Symbol GW, GM.

b. Graded in accordance with SCDOT Standard Specifications, #57 stone and/or #67 stone.

G. Fine Aggregate Base for Slabs-on-Grade: Drainage Course – Sand:

1. Natural river or bank sand; washed; free of silt, clay, loam, friable or soluble materials, and organic matter.

a. Graded in accordance with SCDOT Standard Specifications.

b. Graded in accordance with ASTM D2487 Group Symbol SW, SM.

c. Graded in accordance with ASTM C136; within the following limits:

1) No. 4 sieve: 100-percent passing.

2) No. 14 sieve: 10 to 100-percent passing.

3) No. 50 sieve: 5 to 90-percent passing.

4) No. 100 sieve: 4 to 30-percent passing. 5) No. 200 sieve: 0-percent passing.

H. Medium Aggregate Base for Sidewalks and Pads – Pea Gravel:

1. Natural Stone, Pea Gravel; washed; free of clay, shale, and organic matter.

a. Graded in accordance with ASTM D2487 Group Symbol GM, GC.

b. Graded in accordance with ASTM C136, within the following limits:

1) Minimum Size: 1/4-inch.

2) Maximum Size: 5/8-inch

I. Fine Aggregate Base for Sidewalks and Pads – Sand:

1. Natural river or bank sand; washed; free of silt, clay, loam, friable or soluble materials, and organic matter.

a. Graded in accordance with SCDOT Standard Specifications.

b. Graded in accordance with ASTM D2487 Group Symbol SW, SM.

c. Graded in accordance with ASTM C136; within the following limits:

1) No. 4 sieve: 100-percent passing.

2) No. 14 sieve: 10 to 100-percent passing.

3) No. 50 sieve: 5 to 90-percent passing.

4) No. 100 sieve: 4 to 30-percent passing.

2. No. 200 sieve: 0-percent passing.

J. Macadamized Aggregate Base Course for Roads and Parking Areas:

1. In accordance with SCDOT Standard Specifications, Section 305.

K. Herbicide: Commercial chemical for weed control, registered by the EPA. Provide in granular, liquid, or wettable powder form.

2.2 SOURCE QUALITY CONTROL

A. See Division 1 Specification Sections for general requirements for testing and analysis of aggregate materials.

B. Where aggregate materials are specified using ASTM D2487 classification, test and analyze samples for compliance before delivery to project site.

- C. Where aggregate materials are specified using ASTM D2487 classification, testing and analysis of samples for compliance will be provided before delivery to project site.
- D. If tests indicate materials do not meet specified requirements, change material and retest.
- E. Provide materials of each type from same source throughout the Work.

2.3 ACCESSORIES

A. Separation Fabric: Woven geotextile, specifically manufactured for use as a separation geotextile; made from polyolefins, polyesters, or polyamides; and with the following minimum properties determined according to SCDOT Standard Specifications Section 804.11 (2000), ASTM D4759, and referenced standard test methods:

1. Grab Tensile Strength: 200 lbs.; ASTM D4632.
2. Tear Strength: 80 lbs.; ASTM D4533.
3. Puncture Resistance: 80 lbs.; ASTM D4833.
4. Water Flow Rate: 4 gpm per sq. ft.; ASTM D4491.
5. Apparent Opening Size: No. 30; ASTM D4751.

PART 3 - EXECUTION

3.1 EXAMINATION

- A. Verify that substrate has been inspected, gradients and elevations are correct, and is dry.

3.2 PREPARATION

A. The subgrade shall be brought to the line and grade necessary to accommodate the base and pavement at the required finish grades. All subgrade shall be proof-rolled before base course is placed on the subgrade. Proof-rolling should be performed with a loaded tandem dump truck (15cuyd heaped) or as specified in SCDOT Standard Specifications. Test rolling shall be performed parallel to the centerline at speeds between 2 and 5-miles per hour.

B. The surface of the base course will be inspected by the Owner for adequate compaction and surface tolerances. Any ruts or soft yielding spots that may appear in the base course, any areas having inadequate compaction, and any deviations of the surface from the requirements specified for the base course shall be corrected by loosening the affected areas, removing unsatisfactory materials, adding approved materials where required, and by reshaping and re-compacting to line and grade to the specified density requirements.

C. Compaction of the base course materials shall be performed by conventional means using a 30,000 to 40,000 lbs vibratory roller or other means of obtaining the required compaction.

D. Correct irregularities in substrate gradient and elevation by scarifying, reshaping, and recompacting.

E. Do not place aggregate on soft, muddy, or frozen surfaces.

3.3 INSTALLATION

A. Spread aggregate base course over prepared subgrade to a total compacted thickness as indicated in the Construction Details, per pavement section type, of the Drawings.

B. The aggregate shall be spread on the subgrade with a mechanical spreader capable of placing the material to uniform loose depth and without segregation of aggregate, except for areas inaccessible to a mechanical spreader. The aggregate material may be placed by other methods approved by the Owner.

C. Place aggregate base course in the following layer thicknesses and roller compact.

1. If total thickness is 6-inches or less, place aggregate in one (1) layer.
2. If total thickness is greater than 6-inches, place aggregate in maximum 4-inch lifts to desired total thickness.

D. No base course material shall be placed on frozen or wet subgrade or base. Hauling equipment shall not be operated on subgrade.

E. Utilize methods of handing, hauling, and placing aggregate which will minimize segregation and contamination of

aggregate materials.

- F. Aggregate which is contaminated with foreign materials to the extent that the base course will not adequately serve its intended use shall be removed and replaced with acceptable materials by the Contractor at no additional cost to the Owner.
- G. Level and contour surfaces to elevations and gradients indicated.
- H. Add small quantities of fine aggregates to coarse aggregates as appropriate to assist in compaction.
- I. Compact placed aggregate materials to achieve compaction as specified in Sections 31 20 00 – Earth Moving.
- J. Add water to assist in compaction, if necessary. If excess water is apparent, remove aggregate and aerate to reduce moisture.
- K. Use manual tamping equipment in areas inaccessible to roller compaction equipment.
- L. Apply primer coat to finished surfaces under roads and parking areas in conformance with SCDOT Standard Specifications Sections 401.28. See Section 32 12 16 – Hot-Mix Asphalt Concrete Pavement to addition requirements.

3.4 TOLERANCES:

- A. Flatness: Maximum variation of 1/4-inch measured with a 10-foot straight edge.
- B. Scheduled Compacted Thickness: Plus or minus 1/4-inch from required thickness.
- C. Variation from Design Elevation: Plus or minus 1/2-inch from required elevation.

3.5 FIELD QUALITY CONTROL

- A. See Division 1 Specification Sections for general requirements for field inspection and testing.
- B. Testing Agency: The Owner will engage a qualified independent geotechnical engineering testing agency to perform field quality control testing.
- C. Allow Testing Agency to inspect and test subgrades. Proceed with aggregate base course placement only after test results for previously completed work comply with requirements.
- D. Testing Agency will test compaction of aggregate base course in place according to ASTM D1556, ASTM D2167, ASTM D2922, and ASTM D2937, as applicable and to the current edition of SCDOT Standard Specifications. Tests will be performed at the following locations and frequencies:
 - 1. Paved and Building Slab Areas: At subgrade and at each compacted aggregate base course layer, at least one (1) test for every 2,000 sq. ft. or less of paved area or building slab, but in no case fewer than three (3) tests.
- E. Testing Agency will test compaction of aggregate base course in place according to the current edition of SCDOT Standard Specifications. Tests will be performed at the following locations and frequencies:
 - 1. Roadway Areas: At subgrade and at each compacted aggregate base course layer, at least one (1) test for every 3,600 sq. ft. or less of paved area, but in no case fewer than two (2) tests.
- F. If test indicate Work does not meet specified requirements, remove Work, replace and retest at no additional cost to the Owner.
- G. Proof roll compacted aggregate base courses at surfaces that will be under slabs-on-grade, pavers, and pavements.

3.6 CLEAN-UP

- A. Remove unused stockpiled material, leave area in a clean and neat condition. Grade stockpile area to prevent standing water.

END OF SECTION 32 1000

SECTION 32 18 16

ARTIFICIAL GRASS – SLIT-FILM/MONOFILAMENT 2.5”

PART 1 - GENERAL

1.1 SUMMARY

A. Furnish all labor, materials, tools, and equipment necessary to install slit-film/monofilament artificial grass as indicated on the plans and as specified herein; including components and accessories required for a complete installation. including but not limited to:

1. Acceptance of prepared sub-base.
2. Coordination with related trades to ensure a complete, integrated, and timely installation: Aggregate base course, sub-base material (tested for permeability), grading and compacting, piping and drain components (when required); as provided under its respective trade section.

1.2 RELATED SECTIONS

A. Section Series 32 13 23 - Aggregate Base Courses

1.3 REFERENCE STANDARDS

A. FM Factory Mutual

1. P7825 - Approval Guide; Factory Mutual Research Corporation; current edition

B. ASTM – American Society for Testing and Materials.

1. D1907 - Standard Test Method for Denier
2. D5848 - Standard Test Method for Mass Per Unit Area of Pile Yarn Floor Covering
3. D1338 - Standard Test Method for Tuft Bind of Pile Yarn Floor Covering
4. D1682 - Standard Method of Test for Breaking Load and Elongation of Textile Fabrics
5. D5034 - Standard Test Method of Breaking Strength and Elongation of Textile Fabrics (Grab Test)
6. F1551 - Standard Test Method for Water Permeability
7. D2859 - Standard Test Method for Ignition Characteristics of Finished Textile Floor Covering Materials
8. F355 - Standard Test Method for Shock-Absorbing Properties of Playing Surfaces.
9. F1936 - Standard Test Method for Shock-Absorbing Properties of North American Football Field Playing Systems as Measured in the Field

1.4 QUALITY ASSURANCE

A. Comply with Section 01 43 00, Quality Assurance.

B. Manufacturer Qualifications: Company specializing in manufacturing products specified in this section. The turf contractor and/or the turf manufacturer:

1. Shall be experienced in the manufacture and installation of slit-film/monofilament grass turf for a minimum of three years. This includes use of a slitfilm/monofilament fiber, and the installation method.
2. Shall have 100 fields in play for at least two years. Fields shall be 65,000 ft² or more.
3. Turf manufacturer shall have installed a minimum of 5 fields that are at least 8 years old, which is equal to the respective warranty period.
4. Shall have a minimum of 50 installations in the State of South Carolina.

5. Shall have a minimum of 100 installations in North America with a slitfilm/monofilament fiber, each field of 65,000 ft² or more.

C. Installer: Company shall specialize in performing the work of this section. The Contractor shall provide competent workmen skilled in this specific type of synthetic grass installation.

1. The designated Supervisory Personnel on the project shall be certified, in writing by the turf manufacturer, as competent in the installation of specified slitfilm/monofilament material, including sewing seams and proper installation of the infill mixture.
2. Installer shall be certified by the manufacturer and licensed.
3. The installer supervisor shall have a minimum of 5 years experience as either a construction manager or a supervisor of synthetic turf installations

D. Pre-Installation Conference: Conduct conference at project site at time to be determined by Owner Review methods and procedures related to installation including, but not limited to, the following:

1. Inspect and discuss existing conditions and preparatory work performed under other contracts.
2. In addition to the Contractor and the installer, arrange for the attendance of installers affected by the Work, The Owner's representative, and the Engineer.

E. The Contractor shall verify special conditions required for the installation of the system.

F. The Contractor shall notify the owner of any discrepancies.

1.5 DELIVERY, STORAGE, AND HANDLING

A. Comply with Section 01 60 00, Product Requirements.

B. Prevent contact with materials that may cause dysfunction.

C. Deliver and store components with labels intact and legible.

D. Store materials/components in a safe place, under cover, and elevated above grade.

E. Protect from damage during delivery, storage, handling and installation. Protect from damage by other trades.

F. Inspect all delivered materials and products to ensure they are undamaged and in good condition.

1.6 SEQUENCING AND SCHEDULING

A. Coordinate the Work with installation of work of related trades as the Work proceeds.

B. Sequence the Work to prevent deterioration of installed system.

1.7 WARRANTY AND GUARANTEE

A. See Section 01780 - Closeout Submittals, For Additional Warranty Requirements.

B. The Contractor shall provide a warranty to the Owner that covers defects in materials and workmanship of the turf for a period of eight (8) years from the date of substantial completion. The turf manufacturer must verify that their representative has inspected the installation and that the work conforms to the manufacturer's requirements. The manufacturer's warranty shall include general wear and damage caused from UV degradation. The warranty shall specifically exclude vandalism, and acts of God beyond the control of the Owner or the manufacturer. The warranty shall be fully third-party insured; prepaid for the entire 8 year term and be non-prorated. The Contractor shall provide a warranty to the Owner that covers defects in the installation workmanship, and further warrant that the installation was done in accordance with both the manufacturer's recommendations and any written directives of the manufacturer's representative. Prior to final payment for the synthetic turf, the Contractor shall submit to owner notification in writing that the field is officially added to the annual policy coverage, guaranteeing the warranty to the Owner. The insurance policy must be underwritten by an "AM Best" A rated

carrier and must reflect the following values:

- Pre-Paid 8-year insured warranty from a single source. • Maximum per claim coverage amount of \$15,000,000.
- Minimum of fifteen million dollars (\$15,000,000) annual.
- Must cover full 100% replacement value of total square footage installed, minimum of \$7.00 per sq ft. (in case of complete product failure, which will include removal and disposal of the existing surface)
- Provide a sample copy of insured, non-prorated warranty, and insurance policy information.
- Policy cannot include any form of deductible to be paid by the Owner.

C. The artificial grass system must maintain a G-max of less than 200 for the life of the Warranty as per ASTM F1936

1.8 MAINTENANCE SERVICE

A. Contractor shall train the Owner's facility maintenance staff in the use of the turf manufacturer's recommended maintenance equipment.

B. Manufacturer must provide maintenance guidelines to the facility maintenance staff.

PART 2 - PRODUCTS

2.1 ACCEPTABLE MANUFACTURER

A. Approved manufacturers are as follows:

1. FieldTurf USA
175 N. Industrial Blvd
Calhoun, GA 30701
P: 800-724-2969

Model: FieldTurf Vertex-65

2. Competitor A: AstroTurf
Model: 3D3 2.5" - Infill: 3.5lbs./sf rubber and 4lbs./sf sand

3. Competitor B: Shaw
Model: Legion 2.5" - Infill: 3.5lbs./sf rubber and 4lbs./sf sand

*Alternate 1: FieldTurf Vertex Core– FTVTC-1+ Cooling Composite

2.2 MATERIALS AND PRODUCTS – BASE BID

A. Artificial grass system materials shall consist of the following:

1. Carpet made of slit-film/monofilament polyethylene fibers tufted into a perforated backing. Alternating row monofilament and slit-film carpet constructions are not permitted.
2. Infill: Graded sand and ambient rubber that partially covers the carpet.
3. Glue, thread, paint, seaming fabric and other materials used to install and mark the artificial grass slit-film/monofilament turf.

B. The installed artificial grass slit-film/monofilament turf shall have the following properties:

Standard	Property	Specification
ASTM D1907	Yarn Structure – A	Slit-Film
	Yarn Denier - A	5,000+
ASTM D5823	Yarn Structure – B	Ridged Monofilament
	Yarn Denier – B	11,000+
ASTM D1577	Min. Pile Height	2.5”
ASTM D5848	Fiber Thickness A/B	100+/360 Microns ASTM D5793
ASTM D5848	Stitch Gauge	3/8” - 3/4”
ASTM D5848	Pile Weight	47+oz/square yard
ASTM D5848	Primary Backing	7+oz/square yard
ASTM D5848	Secondary Backing	16+oz/square yard
ASTM D5848	Total Weight	70+oz/square yard
ASTM D1335	Tuft Bind (Without Infill)	8+lbs
ASTM D5034	Grab Tear (Width)	200 lbs/force
ASTM D5034	Grab Tear (Length)	200 lbs/force
ASTM F1551	Carpet Permeability	>40 inches/hour
ASTM F1936	Impact Attenuation (Gmax)	<200
	Min. Infill Material Depth	1.75 inches
	Min. Sand Infill Component	4lbs/square foot
	Min. Rubber Infill	3.5lbs/square foot
	Total Product Weight	1150+oz/square yard

Variation of +/- 5% on above listed properties is within normal manufacturing tolerances.

- C. Carpet shall consist of slit-film/monofilament fibers tufted into a primary backing with a secondary backing.
- D. Carpet Rolls shall be 15’ wide rolls.
 - 1. Rolls shall be long enough to go from field sideline to sideline.
 - 2. Where the playing field is for football, the perimeter white line shall be tufted into the individual sideline rolls.
- E. Backing:
 - 1. Primary backing shall be a minimum double-layered polypropylene fabric.
 - 2. Secondary backing shall permanently lock the fiber tufts in place.
 - 3. Perforated (with punched holes), backed carpet are acceptable. F. Fiber shall be measuring no less than 2 ½ inches high.
- 1. Systems with less than a 2 ½ inch fibers are unacceptable.
- G. Infill materials shall be approved by the manufacturer.
 - 1. The infill shall consist of a resilient-layered, granular system, comprising selected graded sand and ambient rubber.
- H. The sand infill will comply within the following characteristics:
 - Average Particle size between 20 and 30 mesh [calculated based on summing the midpoint of sieve pan fractions times the % retained on given screen fractions]
 - Average Particle shape > 0.4 on the Krumbein scale
 - Particle structure predominantly single grain
 - Produce < 0.4%, -50M in API crush test at 80psig
- I. Non-tufted or inlaid lines and markings shall be painted with paint approved by the synthetic turf manufacturer.
- J. Thread for sewing seams of turf shall be as recommended by the synthetic turf manufacturer.

- K. Glue and seaming fabric for inlaying lines and markings shall be as recommended by the synthetic turf manufacturer.

MATERIALS AND PRODUCTS – ALTERNATE

Model: FieldTurf FieldTurf Vertex Core – FTVTC-1+ Cooling Composite.

A. Artificial grass FieldTurf system materials shall consist of the following:

1. Carpet made of slit-film/monofilament polyethylene fibers tufted into a fibrous, non-perforated, porous backing. Alternating row monofilament and slit-film carpet constructions are not permitted. Monofilament fibers shall be 14,000 denier, slitfilm fibers shall be 5000 denier - both fibers shall be low friction, and UV-resistant, measuring not less than 2.5 inches high. Each monofilament fiber is extruded with two layers of polyethylene polymers. A rigid polyethylene polymer as the inner core of the fiber for superior resilience and a soft yet extremely durable polyethylene polymer as the outer shell of the fiber for a realistic grass-like feel.
2. Infill: graded sand and cryogenic rubber crumb and an extruded cooling composite particle that partially covers the carpet.
3. Glue, thread, paint, seaming fabric and other materials used to install and mark the artificial grass slit-film/monofilament FieldTurf.
4. Warranty on the alternate shall be a ten (10) year third-party insured warranty.

B. The installed artificial grass slit-film/monofilament FieldTurf shall have the following properties:

<u>Standard</u>	<u>Property</u>	<u>Specification</u>
•		Pile Yarn Type
•		UV-resistant polyethylene
•		Yarn Structure – A
•	ASTM D1907	Slit-Film
•		Yarn Denier - A
•		5,000
•		Yarn Structure – B
•		Ridged Monofilament
•		Yarn Denier – B
•	ASTM D5823	14,000+
•		Min. Pile Height
•	ASTM D1577	2.5”
•		Fiber Thickness A/B
•	ASTM D5793	130/360 Microns
•		Stitch Gauge
•	ASTM D5848	3/4”
•		Pile Weight
•	ASTM D5848	42oz/square yard
•		Primary Backing
•	ASTM D5848	7+oz/square yard
•		Secondary Backing
•	ASTM D5848	14+oz/square yard
•		Total Weight
•	ASTM D1335	68+oz/square yard
•		Tuft Bind (Without Infill)
•	ASTM D5034	8+lbs
•		Grab Tear (Width)
•	ASTM D5034	200 lbs/force
•		Grab Tear (Length)
•	ASTM F1551	200 lbs/force
•		Carpet Permeability
•	ASTM F1936	>40 inches/hour
•		Impact Attenuation (Gmax)
•		<200
•		Min. Infill Material Depth
•		1.75 inches
•		Min. Extruded Cooling Composite
•		0.6lbs/square foot
•		Min. Sand Infill Component
•		6.2lbs/square foot
•		Min. Cryogenic Rubber Infill
•		2.4lbs/square foot
•		Total Product Weight
•		1393oz/square yard

Variation of +/- 5% on above listed properties is within normal manufacturing tolerances

C. Carpet shall consist of slit-film/monofilament fibers tufted into a primary backing with a secondary backing.

D. Carpet Rolls shall be 15’ wide rolls.

1. Rolls shall be long enough to go from field sideline to sideline.
2. Where the playing field is for football, the perimeter white line shall be tufted into the individual sideline

rolls.

- E. Backing:
1. Primary backing shall be a minimum double-layered polypropylene fabric
 2. Secondary backing shall permanently lock the fiber tufts in place.
 3. Perforated (with punched holes), backed carpet is unacceptable.
- F. Fiber shall be measuring no less than 2 1/2 inches high.
1. Systems with less than a 2 1/2-inch fibers are unacceptable.
- G. Infill materials shall be approved by the manufacturer.
1. Infill shall consist of a resilient layered granular system, comprising selected and graded sand, cryogenically hammer-milled SBR rubber crumb and an extruded cooling composite.
 2. Artificial Grass products without cryogenically processed SBR rubber and a top layer of the extruded cooling composite will not be acceptable.
 3. Coated infill and infill needing to be watered to activate their cooling properties are unacceptable.
 4. The extruded cooling composite must have a bulk density of 0.55 g/cm³ +/- 15% and a specific gravity of greater than 1.
 5. Shall provide third-party laboratory testing proving heat reduction qualities of the same infill materials used in the proposed turf system including the top layer extruded cooling composite.
 6. Shall have a minimum of 100 references of fields installed with an extruded cooling composite installed as the top layer of infill.
- H. The sand infill will comply within the following characteristics:
- Average Particle size between 20 and 30 mesh [calculated based on summing the midpoint of sieve pan fractions times the % retained on given screen fractions]
 - Average Particle shape > 0.4 on the Krumbein scale
 - Particle structure predominantly single grain
 - Produce < 0.4%, -50M in API crush test at 80psig
- I. Non-tufted or inlaid lines and markings shall be painted with paint approved by the synthetic turf manufacturer.
- J. Thread for sewing seams of turf shall be as recommended by the synthetic turf manufacturer.
- K. Glue and seaming fabric for inlaying lines and markings shall be as recommended by the synthetic turf manufacturer.

2.3 QUALITY CONTROL IN MANUFACTURING

- A. The manufacturer shall own and operate its own manufacturing plant in North America.
- B. The manufacturer's full-time in-house certified inspectors shall perform pre-tufting fiber testing on tensile strength, elongation, tenacity, denier, shrinkage, and twist i.e., turns per inch, upon receipt of fiber spools from fiber manufacturer.
- C. The manufacturer shall have its own, in-house laboratory where samples of turf are retained and analyzed, based on standard industry tests, performed by full-time, in-house, certified inspectors.

2.4 FIELD GROOMER & SWEEPER

Supply field groomer as part of the work.

1. Field Sweeper shall be a FieldTurf FieldSweep or equivalent.

PART 3 - EXECUTION

3.1 EXAMINATION

- A. Verify that all sub-base leveling is complete prior to installation.
- B. Installer shall examine the surface to receive the synthetic turf and accept the sub-base planarity in writing prior to the beginning of installation.
 1. Acceptance is dependent upon the Owner's test results indicating compaction and planarity follow manufacturer's specifications.
 2. The surface shall be accepted by Installer as "clean" as installation commences and shall be maintained in that condition throughout the process.
- C. Compaction of the aggregate base shall be 95%, in accordance with ASTM D1557 (Modified Proctor procedure); and the surface tolerance shall not exceed 0-1/4 inch over 10 feet and 0-1/2" from design grade.
- D. Correct conditions detrimental to timely and proper completion of Work.
- E. Do not proceed until unsatisfactory conditions are corrected.
- F. Beginning of installation means acceptance of existing conditions.

3.2 PREPARATION

- A. Prior to the beginning of installation, inspect the sub-base for tolerance to grade.
- B. Sub-base acceptance shall be subject to receipt of test results (by others) for compaction and planarity that sub-base follows manufacturer's specifications and recommendations.
- C. Dimensions of the field and locations for markings shall be measured by a registered surveyor to verify conformity to the specifications and applicable standards. A record of the finished field as-built measurements shall be made.
- D. When requested by Owner, installed sub-base shall be tested for porosity prior to the installation of the slit-film/monofilament turf. A subbase that drains poorly is an unacceptable substrate.

3.3 INSTALLATION - GENERAL

- A. The installation shall be performed in full compliance with approved Shop Drawings.
- B. Only trained technicians, skilled in the installation of athletic caliber synthetic turf systems working under the direct supervision of the approved installer supervisors, shall undertake any cutting, sewing, gluing, shearing, topdressing or brushing operations.
- C. The designated Supervisory personnel on the project must be certified, in writing by the turf manufacturer, as competent in the installation of this material, including sewing seams and proper installation of the Infill mixture.
- D. Designs, markings, layouts, and materials shall conform to all currently applicable National Collegiate Athletic Association rules, NFHS rules, and/or other rules or standards that may apply to this type of synthetic grass installation. Designs, markings and layouts shall first be approved by the Owner in the form of final shop drawings. All markings will be in full compliance with final shop drawings.

3.4 INSTALLATION

- A. Install at location(s) indicated, to comply with final shop drawings, manufacturers'/installer's instructions.
- B. The Contractor shall strictly adhere to specified procedures. Any variance from these requirements shall be provided in writing, by the manufacturer's on-site representative, and submitted to the Owner, verifying that the changes do not in any way affect the Warranty. Infill materials shall be approved by the manufacturer and installed in accordance with the manufacturer's standard procedures.
- C. Carpet rolls shall be installed directly over the properly prepared aggregate base. Extreme care shall be taken to avoid disturbing the aggregate base, both regarding compaction and planarity.
 - 1. Repair and properly compact any disturbed areas of the aggregate base as recommended by manufacturer.
- D. Full width rolls shall be laid out across the field.
 - 1. Turf shall be of sufficient length to permit full cross-field installation from sideline to sideline.
 - 2. Each roll shall be attached to the next roll utilizing standard state-of-the-art sewing procedures.
 - 3. When all the rolls of the playing surface have been installed, the sideline areas shall be installed at right angles to the playing surface.
- E. Artificial turf panel seams shall be sewn. Other than extension inlays, seams secured by other means including gluing are unacceptable. Installation shall be 99% sewn.
 - 1. Minimum gluing will only be permitted to repair problem areas, corner completions, and to cut in any logos or inlaid lines as required by the specifications.
 - 2. Seams shall be flat, tight, and permanent with no separation or fraying.
 - 3. In the case of all lines and logos, turf carpet must be sheared to the backing (do not cut the backing) and adhered using hot melt adhesives.
- F. Infill Materials:
 - 1. Infill materials shall be applied in numerous thin lifts. The turf shall be brushed as the mixture is applied. The infill material shall be installed to a depth determined by the manufacturer.
 - 2. Infill materials shall be installed to fill the voids between the fibers and allow the fibers to remain vertical and non-directional. The Infill installation consists of a base layer of sand followed by a final application of specifically sized rubber that completes the system. The Infill shall be installed to the depth of minimum 1.75".
- G. Non-tufted or inlaid lines and markings shall be painted in accordance with turf and paint manufacturers' recommendations. Number of applications will be dependent upon installation and field conditions.
- H. Synthetic turf shall be attached to the perimeter edge detail in accordance with the manufacturer's standard procedures.
- I. Upon completion of installation, the finished field shall be inspected by the installation crew and an installation supervisor.

3.5 FIELD MARKINGS

- A. Field markings shall be installed in accordance with approved shop drawings. If football is designated as the primary sport, all five-yard lines will be tufted-in.
- B. Balance of sports markings will be inlaid or painted in accordance with the Drawings.
- C. Center field logo shall be either painted or inlaid according to artwork indicated on Drawings and in accordance with manufacturer's standard palette of turf colors.
- D. End-zone letters and logos shall be either painted or inlaid according to artwork and fonts indicated on the Drawings,

and in accordance with manufacturer's standard palette of turf colors.

3.6 ADJUSTMENT AND CLEANING

- A. Do not permit traffic over unprotected surface.
- B. Contractor shall provide the labor, supplies, and equipment as necessary for final cleaning of surfaces and installed items.
- C. All usable remnants of new material shall become the property of the Owner.
- D. The Contractor shall keep the area clean throughout the project and clear of debris.
- E. Surfaces, recesses, enclosures, and related spaces shall be cleaned as necessary to leave the work area in a clean, immaculate condition ready for immediate occupancy and use by the Owner.

3.7 PROTECTION

- A. Protect installation throughout construction process until date of final completion.

GENERAL CONSTRUCTION NOTES:

- ALL COMMUNICATION FOR THIS PROJECT SHALL BE COORDINATED WITH THE OWNER'S REPRESENTATIVE. ANY DIRECT CONTACT BETWEEN CONTRACTOR-OWNER, CONTRACTOR-ARCHITECT AND CONTRACTOR/ENGINEER SHALL BE COORDINATED WITH THE OWNER'S REPRESENTATIVE.
- THE CONTRACTOR SHALL FURNISH ALL MATERIALS, EQUIPMENT, AND LABOR NECESSARY TO COMPLETE ALL WORK AS INDICATED ON THE CONSTRUCTION DOCUMENTS.
- THE CONTRACTOR SHALL VISIT THE JOB SITE AND BE RESPONSIBLE FOR REVIEWING CONTRACT DOCUMENTS, FIELD CONDITIONS, DIMENSIONS AND CONFIRMING THAT THE WORK MAY BE ACCOMPLISHED AS SHOWN PRIOR TO PROCEEDING WITH CONSTRUCTION.
- ANY DISCREPANCIES ARE TO BE BROUGHT TO THE ATTENTION OF THE ARCHITECT/ENGINEER/owner's representative PRIOR TO PROCEEDING WITH THE WORK.
- THE CONTRACTOR SHALL RECEIVE, IN WRITING, AUTHORIZATION TO PROCEED BEFORE STARTING WORK ON ANY ITEM NOT CLEARLY DEFINED OR IDENTIFIED BY THE CONTRACT DOCUMENTS.
- THE CONTRACTOR SHALL INSTALL ALL EQUIPMENT AND MATERIALS IN ACCORDANCE WITH MANUFACTURER'S RECOMMENDATIONS UNLESS SPECIFICALLY INDICATED OTHERWISE OR WHERE LOCAL CODES OR REGULATIONS TAKE PRECEDENCE.
- ALL WORK PERFORMED AND MATERIALS INSTALLED SHALL BE IN STRICT ACCORDANCE WITH ALL APPLICABLE CODES, REGULATIONS AND ORDINANCES.
- THE CONTRACTOR SHALL ASSUME SOLE AND COMPLETE RESPONSIBILITY FOR JOB SITE CONDITIONS DURING THE COURSE OF CONSTRUCTION OF THIS PROJECT INCLUDING SAFETY OF ALL PERSONS AND PROPERTY, THIS REQUIREMENT SHALL APPLY CONTINUOUSLY AND NOT BE LIMITED TO NORMAL WORKING HOURS.
- THE CONTRACTOR SHALL SUPERVISE AND DIRECT THE WORK, USING THE BEST SKILLS AND ATTENTION. THE CONTRACTOR SHALL BE SOLELY RESPONSIBLE FOR ALL CONSTRUCTION MEANS, METHODS, TECHNIQUES, SEQUENCES AND PROCEDURES AND FOR COORDINATING ALL PORTIONS OF THE WORK UNDER THIS CONTRACT.
- DETAILS ARE INTENDED TO SHOW FINAL RESULT OF DESIGN. MINOR MODIFICATIONS MAY BE REQUIRED TO SUIT JOB SITE DIMENSIONS OR CONDITIONS AND SUCH MODIFICATIONS SHALL BE INCLUDED AS PART OF THE WORK.
- THE CONTRACTOR SHALL MAKE ALL NECESSARY PROVISIONS TO PROTECT EXISTING IMPROVEMENTS, ROADWAY, DRAINAGE WAYS, CULVERTS AND VEGETATION UNTIL SUCH ITEMS ARE TO BE DISTURBED OR REMOVED AS INDICATED ON THE CONSTRUCTION DOCUMENTS.
- CONTRACTOR SHALL KEEP JOB SITE ARE CLEAN, HAZARD FREE AND DISPOSE OF ALL DIRT, DEBRIS AND RUBBISH. AT COMPLETION OF THE PROJECT CONTRACTOR SHALL REMOVE ALL MATERIAL AND EQUIPMENT NOT SPECIFIED AS REMAINING ON THE PROPERTY.
- REPRESENTATIONS OF TRUE NORTH SHALL NOT BE USED TO IDENTIFY OR ESTABLISH THE BEARING OF TRUE NORTH AT THIS JOB SITE.
- IT SHALL BE THE RESPONSIBILITY OF THE CONTRACTOR TO LOCATE ALL EXISTING UTILITIES WHETHER SHOWN HEREON OR NOT AND TO PROTECT THEM FROM DAMAGE. CONTRACTOR SHALL CALL UNDERGROUND SERVICE ALERT P.U.P.S. AT 1-800-421-7811 FOR UTILITY LOCATIONS 72 HOURS PRIOR TO START OF CONSTRUCTION.
- SIZE, LOCATION AND TYPE OF ANY UNDERGROUND UTILITIES OR IMPROVEMENTS SHALL BE ACCURATELY NOTED AND PLACED ON AS-BUILT DRAWINGS BY THE CONTRACTOR AND ISSUED TO THE ARCHITECT/ENGINEER AT THE COMPLETION OF THE PROJECT.
- NOTICE OF TERMINATION (NOT) AND AS-BUILTS CAN BE SUBMITTED UPON A MINIMUM OF 10% UNIFORM STABILIZATION.

GENERAL STORM DRAINAGE NOTES:

- ALL INSTALLATION SHALL BE IN ACCORDANCE WITH SCDOT PIPE TRENCHES SC-M-114 "SUPPLEMENTAL TECHNICAL SPECIFICATION FOR PERMANENT PIPE CULVERTS" DATED APRIL 6, 2009.
- ALL CONCRETE PIPES SHALL BE IN ACCORDANCE ASTM-C-16 CLASS III, B WALL.
- HDPE - SMOOTH INTERIOR CORRUGATED PLASTIC PIPES & FITTINGS IN ACCORDANCE WITH ASTM-F-405 MAY BE UTILIZED ONLY WHERE SHOWN AND FROM THE FOLLOWING MANUFACTURER OR APPROVED EQUAL:
 - A.D.S. - N12 MFRD. BY ADVANCED DRAINAGE SYSTEMS, INC.
 - 3300 RIVERSIDE DRIVE, COLUMBUS, OHIO 43221
- PIPE SLOPES SHALL NOT BE DECREASED FROM THOSE SHOWN WITHOUT PRIOR APPROVAL FROM THE ENGINEER.
- CONTRACTOR SHALL FURNISH AND INSTALL ALL BENDS, FITTINGS, ETC. AS REQUIRED TO FACILITATE CONSTRUCTION OF
- SEE STORM DRAINAGE PROFILES FOR ADDITIONAL INFORMATION AND PIPELINE MATERIAL.

GENERAL CONSTRUCTION SEQUENCE:

- RECEIVE NPDES COVERAGE FROM DHEC
- PRE-CONSTRUCTION MEETING (ON-SITE IF MORE THAN 10 DISTURBED AND NON-LINEAR)
- NOTIFY DHEC EQC REGIONAL OFFICE OR OCRM OFFICE 48 HOURS PRIOR TO BEGINNING LAND-DISTURBING ACTIVITIES
- INSTALLATION OF CONSTRUCTION ENTRANCE(S)
- CLEARING & GRUBBING ONLY AS NECESSARY FOR INSTALLATION OF PERIMETER CONTROLS
- INSTALLATION OF PERIMETER CONTROLS (E.G., SILT FENCE)
- CLEARING & GRUBBING ONLY IN AREAS OF BASINS/ TRAPS/ PONDS
- INSTALLATION OF BASINS/ TRAPS/ PONDS AND INSTALLATION OF DIVERSIONS TO THOSE STRUCTURES (OUTLET STRUCTURES MUST BE COMPLETELY INSTALLED AS SHOWN ON THE DETAILS BEFORE PROCEEDING TO NEXT STEP; AREAS DRAINING TO THESE STRUCTURES CANNOT BE DISTURBED UNTIL THE STRUCTURES AND DIVERSIONS TO THE STRUCTURES ARE COMPLETELY INSTALLED)
- CLEARING & GRUBBING OF SITE OR DEMOLITION (SEDIMENT & EROSION CONTROL MEASURES FOR THESE AREAS MUST ALREADY BE INSTALLED)
- ROUGH GRADING
- INSTALLATION OF STORM DRAIN SYSTEM AND PLACEMENT OF INLET PROTECTION AS EACH INLET IS INSTALLED
- FINE GRADING, PAVING, ETC.
- PERMANENT/ FINAL STABILIZATION
- CLEAN-OUT OF DETENTION BASINS THAT WERE USED AS SEDIMENT CONTROL STRUCTURES AND RE-GRADING OF DETENTION POND BOTTOMS: IF NECESSARY, MODIFICATION OF SEDIMENT BASIN RISER TO CONVERT TO DETENTION BASIN OUTLET STRUCTURE
- REMOVAL OF TEMPORARY SEDIMENT & EROSION CONTROL MEASURES AFTER ENTIRE AREA DRAINING TO THE STRUCTURE IS FINALLY STABILIZED (THE DEPARTMENT RECOMMENDS THAT THE PROJECT OWNER/ OPERATOR HAVE THE SUPPP PREPARER OR REGISTRATION EQUIVALENT APPROVE THE REMOVAL OF TEMPORARY STRUCTURES.)
- PERFORM AS-BUILT SURVEYS OF ALL DETENTION STRUCTURES AND SUBMIT TO DHEC OR M&4 FOR ACCEPTANCE.
- FINAL STABILIZATION IS 10% PERMANENT VEGETATIVE COVERAGE ACROSS 100% OF THE CONSTRUCTION SITE. 10% UNIFORM STABILITY MUST BE ACHIEVED PRIOR TO SUBMITTING AS-BUILTS AND FINALIZED N.O.T. TO SCDHEC.
- SUBMIT NOTICE OF TERMINATION (NOT) TO DHEC AS APPROPRIATE.
- NOTE: IF NPDES COVERAGE IS BEING ISSUED AFTER LAND-DISTURBING ACTIVITIES HAVE ALREADY STARTED (E.G., IN RESPONSE TO A NOTICE TO COMPLY, NOTICE OF VIOLATION, OR ENFORCEMENT ACTION), THEN THE CONSTRUCTION SEQUENCE MUST SPECIFICALLY INDICATE THE ITEMS THAT HAVE ALREADY OCCURRED AND THE ITEMS THAT WILL BE OCCURRING AFTER NPDES COVERAGE IS ISSUED.
- NOTE: IF FLOWS FROM OFFSITE AREAS WILL BE DIVERTED AROUND THE SITE AND THE ON-SITE STRUCTURES ARE NOT DESIGNED TO HANDLE FLOWS FROM THE OFFSITE AREAS, THEN THE DIVERSIONS/ PIPING FOR THE OFFSITE FLOWS MUST BE INSTALLED BEFORE LAND-DISTURBING ACTIVITIES BEGIN ON THE SITE: INCLUDE THIS IN THE SEQUENCE. SEDIMENT AND EROSION CONTROL MEASURES FOR THE DISTURBED AREAS FOR THE DIVERSION/ PIPING MUST BE INSTALLED BEFORE THOSE AREAS ARE DISTURBED AND SHOULD BE SHOWN ON THE PLANS.
- NOTE: IF AN EXISTING DETENTION/ SEDIMENT BASIN IS BEING MODIFIED TO HANDLE THE FLOWS FROM THE PROPOSED DEVELOPMENT, THEN IT MUST BE MODIFIED BEFORE LAND-DISTURBING ACTIVITIES BEGIN ON THE SITE. THIS SHOULD BE INCLUDED IN THE SEQUENCE.
- NOTE: INCLUDE INDIVIDUAL LOT DEVELOPMENT/ CONSTRUCTION IN THE SEQUENCE IF THE SITE WILL NOT BE MASS-GRADED.
- NOTE: INSTALLATION OF SOME PERMANENT WATER QUALITY DEVICES SHOULD OCCUR AFTER THE SITE IS STABILIZED: INCLUDE THIS IN THE SEQUENCE. CLEANOUT OF OTHER WATER QUALITY DEVICES THAT WERE USED DURING CONSTRUCTION SHOULD OCCUR AFTER SITE STABILIZATION.
- NOTE: MAINTENANCE OF SEDIMENT AND EROSION CONTROL MEASURES MUST CONTINUE UNTIL THE SITE IS PERMANENTLY STABILIZED AND THE CONTROLS ARE REMOVED.

SEDIMENT AND EROSION CONTROL NOTES:

- IF NECESSARY, SLOPES WHICH EXCEED EIGHT (8) VERTICAL FEET SHOULD BE STABILIZED WITH SYNTHETIC OR VEGETATIVE MATS, IN ADDITION TO HYDROSEEDING. IT MAY BE NECESSARY TO INSTALL TEMPORARY SLOPE DRAINS DURING CONSTRUCTION. TEMPORARY BERMIS MAY BE NEEDED UNTIL THE SLOPE IS BROUGHT TO GRADE.
- STABILIZATION MEASURES SHALL BE INITIATED AS SOON AS PRACTICABLE IN PORTIONS OF THE SITE WHERE CONSTRUCTION ACTIVITIES HAVE TEMPORARILY OR PERMANENTLY CEASED, BUT IN NO CASE MORE THAN FOURTEEN (14) DAYS AFTER WORK HAS CEASED, EXCEPT AS STATED BELOW.
 - WHERE STABILIZATION BY THE 14TH DAY IS PRECLUDED BY SNOW COVER OR FROZEN GROUND CONDITIONS STABILIZATION MEASURES MUST BE INITIATED AS SOON AS PRACTICABLE.
 - WHERE CONSTRUCTION ACTIVITY ON A PORTION OF THE SITE IS TEMPORARILY CEASED, AND EARTH-DISTURBING ACTIVITIES WILL BE RESUMED WITHIN 14 DAYS, TEMPORARY STABILIZATION MEASURES DO NOT HAVE TO BE INITIATED ON THAT PORTION OF THE SITE.
- ALL SEDIMENT AND EROSION CONTROL DEVICES SHALL BE INSPECTED ONCE EVERY CALENDAR WEEK. IF PERIODIC INSPECTION OR OTHER INFORMATION INDICATES THAT A BMP HAS BEEN INAPPROPRIATELY, OR INCORRECTLY, THE PERMITTEE MUST ADDRESS THE NECESSARY REPLACEMENT OR MODIFICATION REQUIRED TO CORRECT THE BMP WITHIN 48 HOURS OF IDENTIFICATION.
- PROVIDE SILT FENCE AND/OR OTHER CONTROL DEVICES, AS MAY BE REQUIRED, TO CONTROL SOIL EROSION DURING UTILITY CONSTRUCTION. ALL DISTURBED AREAS SHALL BE CLEANED, GRADED, AND STABILIZED WITH GRASSING IMMEDIATELY AFTER THE UTILITY INSTALLATION, FILL, COVER, AND TEMPORARY SEEDING AT THE END OF EACH DAY ARE RECOMMENDED. IF WATER IS ENCOUNTERED WHILE TRENCHING, THE WATER SHOULD BE FILTERED TO REMOVE SEDIMENT BEFORE BEING PUMPED BACK INTO ANY WATERS OF THE STATE.
- ALL EROSION CONTROL DEVICES SHALL BE PROPERLY MAINTAINED DURING ALL PHASES OF CONSTRUCTION UNTIL THE COMPLETION OF ALL CONSTRUCTION ACTIVITIES AND ALL DISTURBED AREAS HAVE BEEN STABILIZED. ADDITIONAL CONTROL DEVICES MAY BE REQUIRED DURING CONSTRUCTION IN ORDER TO CONTROL EROSION AND/OR OFFSITE SEDIMENTATION. ALL TEMPORARY CONTROL DEVICES SHALL BE REMOVED ONCE CONSTRUCTION IS COMPLETE AND THE SITE IS STABILIZED.
- THE CONTRACTOR MUST TAKE NECESSARY ACTION TO MINIMIZE THE TRACKING OF MUD ONTO PAVED ROADWAY(S) FROM CONSTRUCTION AREAS AND THE GENERATION OF DUST. THE CONTRACTOR SHALL DAILY REMOVE MUD/SOIL FROM PAVEMENT, AS MAY BE REQUIRED.
- RESIDENTIAL SUBDIVISIONS REQUIRE EROSION CONTROL FEATURES FOR INFRASTRUCTURE AS WELL AS FOR INDIVIDUAL LOT CONSTRUCTION. INDIVIDUAL PROPERTY OWNERS SHALL FOLLOW THESE PLANS DURING CONSTRUCTION OR OBTAIN APPROVAL OF AN INDIVIDUAL PLAN IN ACCORDANCE WITH S.C. REG. 12-300 ET SEQ. AND SCR100000.
- TEMPORARY DIVERSION BERMS AND/OR DITCHES WILL BE PROVIDED AS NEEDED DURING CONSTRUCTION TO PROTECT WORK AREAS FROM UPSLOPE RUNOFF AND/OR TO DIVERT SEDIMENT-LADEN WATER TO APPROPRIATE TRAPS OR STABLE OUTLETS.
- ALL WATERS OF THE STATE (WOS), INCLUDING WETLANDS, ARE TO BE FLAGGED OR OTHERWISE CLEARLY MARKED IN THE FIELD. A DOUBLE ROW OF SILT FENCE IS TO BE INSTALLED IN ALL AREAS WHERE A 50-FOOT BUFFER CAN'T BE MAINTAINED BETWEEN THE DISTURBED AREA AND ALL WOS. A 10-FOOT BUFFER SHOULD BE MAINTAINED BETWEEN THE LAST ROW OF SILT FENCE AND ALL WOS.
- LITTER, CONSTRUCTION DEBRIS, OILS, FUELS, AND BUILDING PRODUCTS WITH SIGNIFICANT POTENTIAL FOR IMPACT (SUCH AS STOCKPILES OF FRESHLY TREATED LUMBER) AND CONSTRUCTION CHEMICALS THAT COULD BE EXPOSED TO STORM WATER MUST BE PREVENTED FROM BECOMING A POLLUTANT SOURCE IN STORM WATER DISCHARGES.
- A COPY OF THE SUPPP INSPECTIONS RECORDS, AND RAINFALL DATA MUST BE RETAINED AT THE CONSTRUCTION SITE OR A NEARBY LOCATION EASILY ACCESSIBLE DURING NORMAL BUSINESS HOURS, FROM THE DATE OF COMMENCEMENT OF CONSTRUCTION ACTIVITIES TO THE DATE THAT FINAL STABILIZATION IS REACHED.
- INITIATE STABILIZATION MEASURES ON ANY EXPOSED STEEP SLOPE (34:1V OR GREATER) WHERE LAND-DISTURBING ACTIVITIES HAVE PERMANENTLY OR TEMPORARILY CEASED, AND WILL NOT RESUME FOR A PERIOD OF 7 CALENDAR DAYS.
- MINIMIZE SOIL COMPACTION AND, UNLESS INFEASIBLE, PRESERVE TOPSOIL.
- MINIMIZE THE DISCHARGE OF POLLUTANTS FROM EQUIPMENT AND VEHICLE WASHING, WHEEL WASH WATER, AND OTHER WASH WATERS. WASH WATERS MUST BE TREATED IN A SEDIMENT BASIN OR ALTERNATIVE CONTROL THAT PROVIDES EQUIVALENT OR BETTER TREATMENT PRIOR TO DISCHARGE.
- MINIMIZE THE DISCHARGE OF POLLUTANTS FROM DEWATERING OF TRENCHES AND EXCAVATED AREAS. THESE DISCHARGES ARE TO BE ROUTED THROUGH APPROPRIATE BMPs (SEDIMENT BASIN, FILTER BAG, ETC.).
- THE FOLLOWING DISCHARGES FROM SITES ARE PROHIBITED:
 - WASTEWATER FROM WASHOUT OF CONCRETE, UNLESS MANAGED BY AN APPROPRIATE CONTROL.
 - WASTEWATER FROM WASHOUT AND CLEANOUT OF STUCCO, PAINT, FORM RELEASE OILS, CURING COMPOUNDS AND OTHER CONSTRUCTION MATERIALS.
 - FUELS, OILS, OR OTHER POLLUTANTS USED IN VEHICLE AND EQUIPMENT OPERATION AND MAINTENANCE; AND
 - SOAPS OR SOLVENTS USED IN VEHICLE AND EQUIPMENT WASHING.
- AFTER CONSTRUCTION ACTIVITIES BEGIN, INSPECTIONS MUST BE CONDUCTED AT A MINIMUM OF AT LEAST ONCE EVERY CALENDAR WEEK AND MUST BE CONDUCTED UNTIL FINAL STABILIZATION IS REACHED ON ALL AREAS OF THE CONSTRUCTION SITE.
- IF EXISTING BMPs NEED TO BE MODIFIED OR IF ADDITIONAL BMPs ARE NECESSARY TO COMPLY WITH THE REQUIREMENTS OF THIS PERMIT AND/OR SC'S WATER QUALITY STANDARDS, IMPLEMENTATION MUST BE COMPLETED BEFORE THE NEXT STORM EVENT WHENEVER PRACTICABLE. IF IMPLEMENTATION BEFORE THE NEXT STORM EVENT IS IMPRACTICABLE, THE SITUATION MUST BE DOCUMENTED IN THE SUPPP AND ALTERNATIVE BMPs MUST BE IMPLEMENTED AS SOON AS REASONABLY POSSIBLE.
- A PRE-CONSTRUCTION CONFERENCE MUST BE HELD FOR EACH CONSTRUCTION SITE WITH AN APPROVED ON-SITE SUPPP PRIOR TO THE IMPLEMENTATION OF CONSTRUCTION ACTIVITIES. FOR NON-LINEAR PROJECTS THAT DISTURB 10 ACRES OR MORE THIS CONFERENCE MUST BE HELD ON-SITE UNLESS THE DEPARTMENT HAS APPROVED OTHERWISE.

GRASSING SPECIFICATIONS

- GRASS/SOIL PREPARATION-
- REMOVE AND DISPOSE OF ALL ROCKS AND DEBRIS LARGER THAN 3/4" IN DIAMETER FROM THESE AREAS.
 - USE A SEED-SLITTER OVER THE ENTIRE AREA UNTIL A MIXTURE OF 180 LBS OF COMMON BERMUDA SEED, 550 LBS OF TURF TYPE FESCUE SEED, AND 500 LBS OF 18-24-12 STARTER FERTILIZER IS INSERTED INTO THE SOIL.
 - AGGRESSIVELY CORE AERATE (4" DEEP) WITH A PLUG CORER OVER THE ENTIRE AREA AND BACK DRAG SOIL INTO ANY LOW PLACES AS NEEDED.
 - BRING IN 40 TONS OF TOPSOIL IN THE AREAS AS SHOWN ON THE DRAWING. 15-20 YARDS ARE NEEDED AT THE FRONT RIGHT OF THE SCHOOL. THE REMAINING SOIL IS TO BE USED AS NEEDED IN AREAS WHERE THE GROUND IS HARD.
 - OVER SEED ALL SHADY AREAS WITH ADDITIONAL TURF TYPE FESCUE SEED AT THE RATE OF 3 LBS PER 1,000 SQ. FT. OR APPROXIMATELY 50 LBS TOTAL.

- HYDROSEED-
- HEAVILY HYDROSEED ALL AREAS USING A MIXTURE OF 180 LBS OF COMMON BERMUDA SEED, 550 LBS OF TURF TYPE FESCUE SEED, 500 LBS OF 18-24-12 STARTER FERTILIZER, 150LBS OF LIME AND 1200-1400 LBS OF WOOD MULCH FIBER.
 - WATER IN ALL AREAS ONE TIME.
- GRASS MATTING-
- PROVIDE BIODEGRADABLE STRAW OR COCONUT FIBER MATTING OVER ALL SLOPED AREAS SHOWN. INCLUDE MANUFACTURER'S RECOMMENDED STEEL WIRE STAPLES, 6-INCHES LONG.
- SEED PROTECTION-
- USE CAUTION TAPE AND STAKES TO BARRICADE OFF ALL SEEDED AREAS SO THAT CHILDREN DO NOT DISTURB WHEN THEY RETURN.

PROJECT TIMELINE- ALL WORK IS TO BE COMPLETED BETWEEN APRIL 16TH AND APRIL 23RD. SCHOOL WILL BE OUT FOR SPRING BREAK

GENERAL GRADING NOTES:

- THIS IS NOT A BALANCED SITE. IT IS THE SITE CONTRACTOR'S RESPONSIBILITY TO HAUL IN OR HAUL OFF DIRT AS NECESSARY TO COMPLETE CONSTRUCTION.
- INSTALLATION OF SOIL EROSION CONTROL MEASURES AND PRACTICES WILL BE IMPLEMENTED PRIOR TO LAND DISTURBING ACTIVITIES
- FINAL GRADING WILL CONSIST OF SPREADING TOPSOIL (4" MINIMUM) TO FINISHED GRADES AS INDICATED ON ALL DISTURBED AREAS.
- EROSION CONTROL MEASURES WILL BE MAINTAINED AT ALL TIMES. ADDITIONAL EROSION AND SEDIMENT CONTROL MEASURES WILL BE INSTALLED AS DETERMINED BY ON-SITE INSPECTION.
- ALL DISTURBED AREAS TO BE SODDED OR HYDROSEEDED ACCORDING TO GRASSING SPECIFICATIONS
- UNTIL THE SITE IS STABILIZED, SEDIMENT SHALL BE REMOVED FROM PONDS AFTER EVERY SIGNIFICANT RAINFALL EVENT (GREATER THAN 0.5 INCHES). AFTER THE SITE IS STABILIZED REGRADE THE PONDS TO DESIGN DEPTH. ANY SEDIMENT REMOVED SHOULD BE PROPERLY DISPOSED OF OR USED ON-SITE.
- ALL EARTHWORK SHALL BE PERFORMED IN ACCORDANCE WITH THE RECOMMENDATIONS AND/OR UNDER THE SUPERVISION OF A SOILS CONSULTANT.

CERTIFICATION STATEMENT

"I have placed my signature and seal on the design documents submitted signifying that I accept responsibility for the design of the system. Further, I certify to the best of my knowledge and belief that the design is consistent with the requirements of Title 48, Chapter 14 of the Code of Laws of SC, 1976 as amended, pursuant to Regulation 72-300 et seq. (if applicable), and in accordance with the terms and conditions of SCR100000."

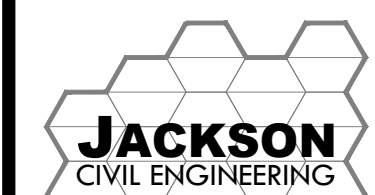
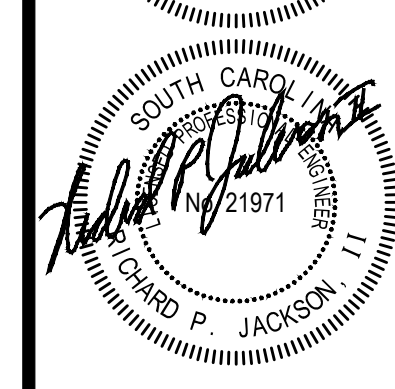
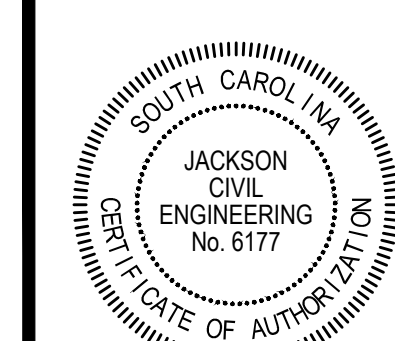

221 Powell Drive
Lexington, SC 29072

SYNTHETIC TURF REPLACEMENT
RIVER BLUFF HIGH SCHOOL
320 CORLEY MILL RD, LEXINGTON, SC 29072
LEXINGTON SCHOOL DIST ONE

Date	Description	No

CONSTR DOCS

DRAWN BY: RPI

CHECKED BY: JCE

PROJECT NO: 2402

DATE: JAN 22, 2024

SHEET TITLE: GENERAL NOTES

SHEET NO:

C101

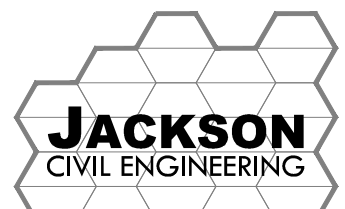
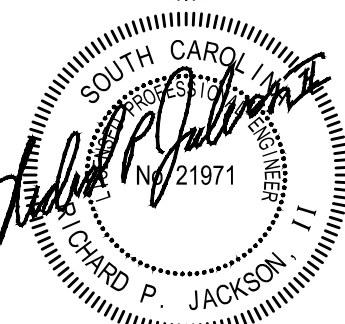
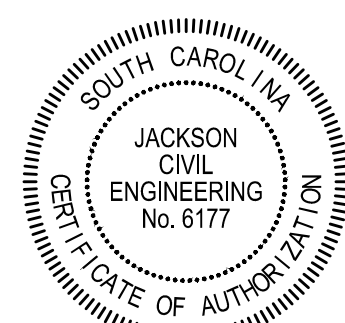
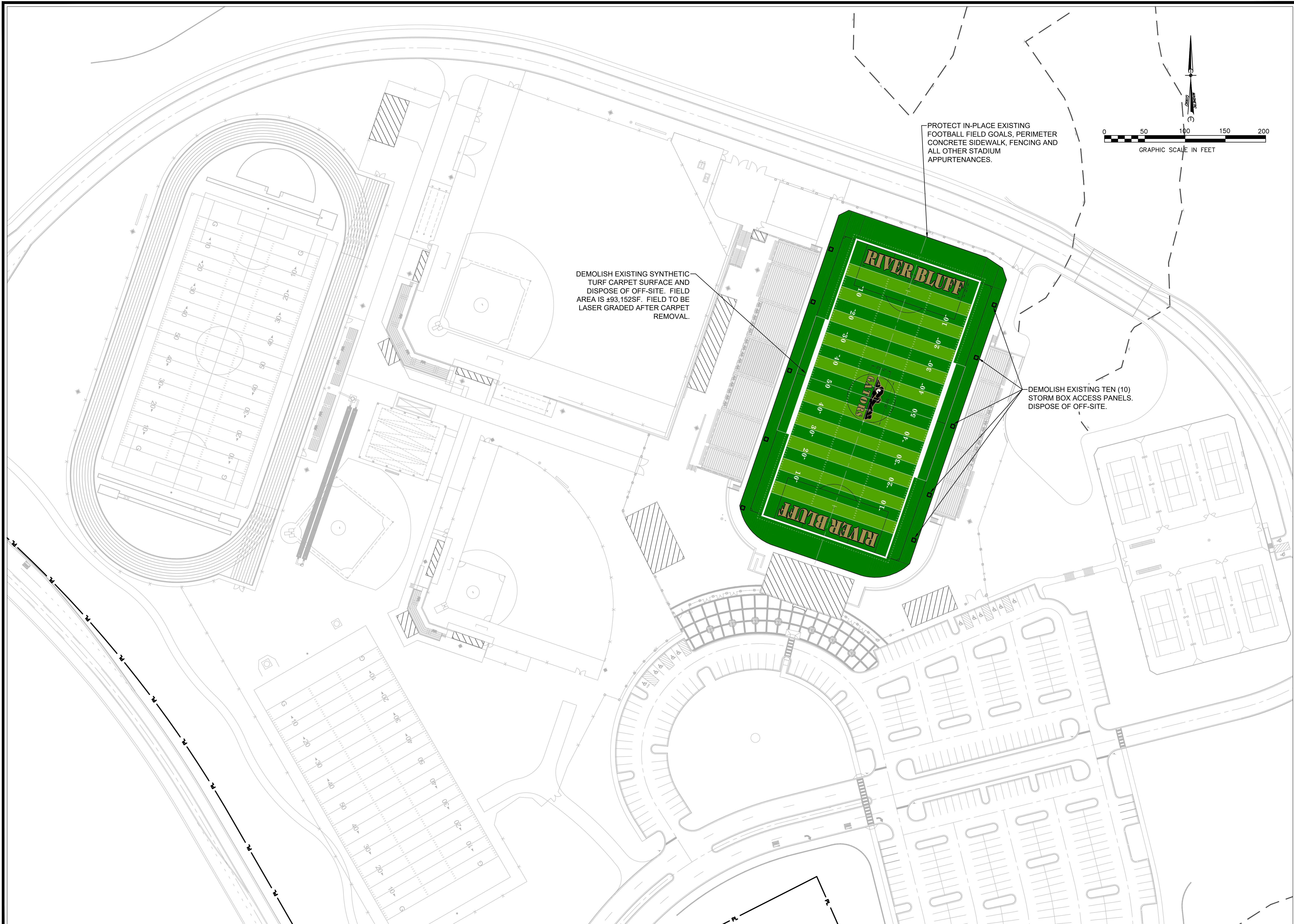

221 Powell Drive
Lexington, SC 29072

SYNTHETIC TURF REPLACEMENT
RIVER BLUFF HIGH SCHOOL
320 CORLEY MILL RD, LEXINGTON, SC 29072
LEXINGTON SCHOOL DIST ONE

No	Description	Date

CONSTR DOCS

DRAWN BY: JCS

CHECKED BY: RPJ

PROJECT NO: 2402

DATE: JAN 22, 2024

SHEET TITLE:

ATHLETIC COMPLEX
CIVIL SITE PLAN

SHEET NO:

C201

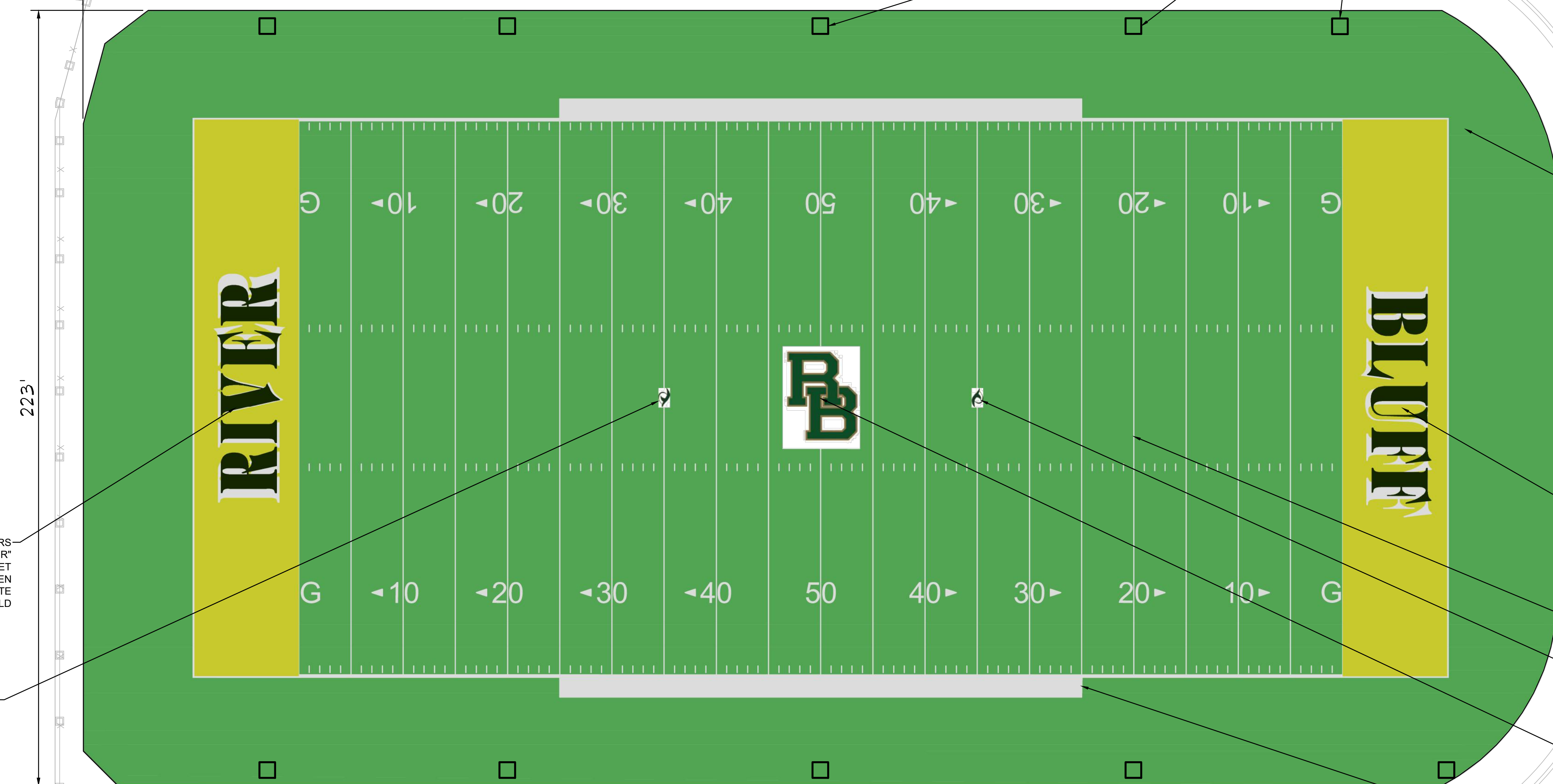
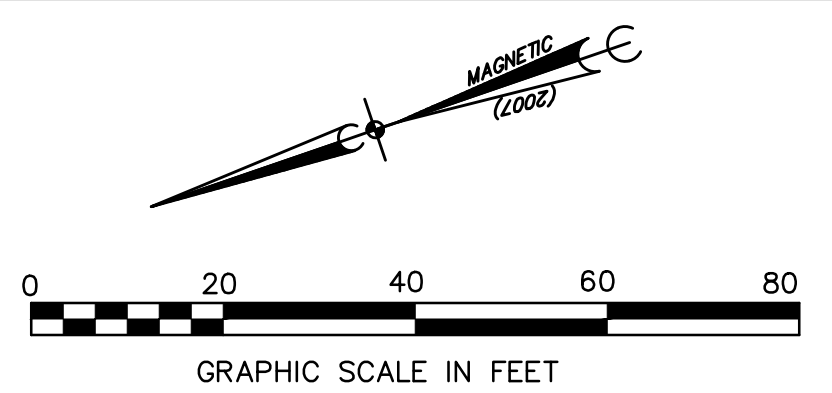

END ZONE LETTERS
 NORTH END ZONE: "RIVER"
 SIZE: 17FEET
 LETTER COLOR: GREEN
 LETTER OUTLINE: WHITE
 END ZONE BACKGROUND: VEGAS GOLD

35 YARD-LINE LOGO
 TYPE: GATOR EYE
 LOGO COLOR: GREEN
 LOGO OUTLINE: VEGAS GOLD

INSTALL NEW TREATED WOOD
 PANEL ACCESS TO THE TEN (10)
 STORM BOXES UNDER THE FIELD
 USING NEW TURF CARPET.

INSTALL NEW 2-1/2" SYNTHETIC TURF ARTIFICIAL
 GRASS CARPET. FIELD AREA IS 493,000SF.
 CONTRACTOR TO IMPORT AND/OR EXPORT GRAVEL
 AS NECESSARY TO ACHIEVE FINISHED GRADE.

END ZONE LETTERS
 SOUTH END ZONE: "BLUFF"
 SIZE: 17FEET
 LETTER COLOR: GREEN
 LETTER OUTLINE: WHITE
 END ZONE BACKGROUND: VEGAS GOLD

FIELD COLOR
 SOLID GREEN

35 YARD-LINE LOGO
 TYPE: GATOR EYE
 LOGO COLOR: GREEN
 LOGO OUTLINE: VEGAS GOLD

MID-FIELD LOGO
 TYPE: RB LOGO
 SIZE: 10YDS
 LETTER COLOR: VEGAS GOLD
 LETTER OUTLINE: WHITE

SIDELINE BORDER
 COLOR: WHITE

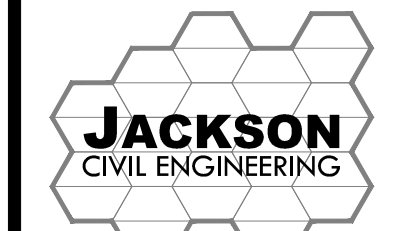
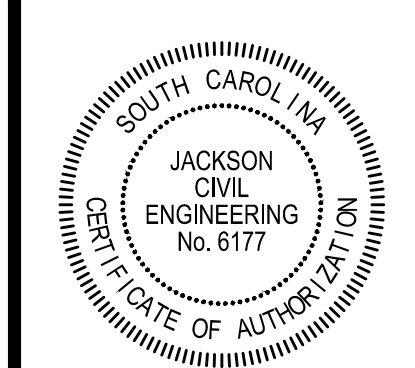

221 Powell Drive
 Lexington, SC 29072

SYNTHETIC TURF REPLACEMENT
 RIVER BLUFF HIGH SCHOOL
 320 CORLEY MILL RD, LEXINGTON, SC 29072
 LEXINGTON SCHOOL DIST ONE

No	Description	Date

CONSTR DOCS

DRAWN BY: RPJ

CHECKED BY: JCE

PROJECT NO: 2402

DATE: JAN 22, 2024

SHEET TITLE:

SITE PLAN

SHEET NO:

C202

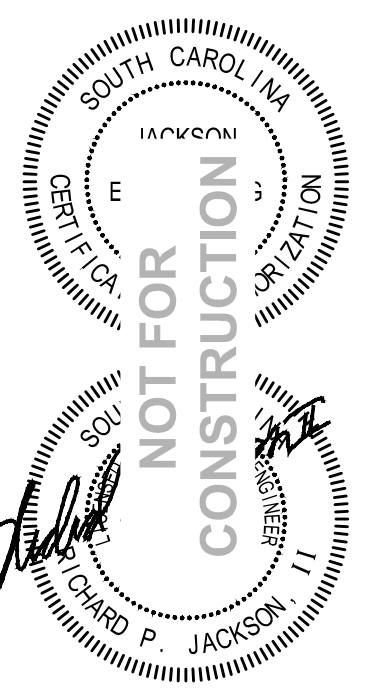
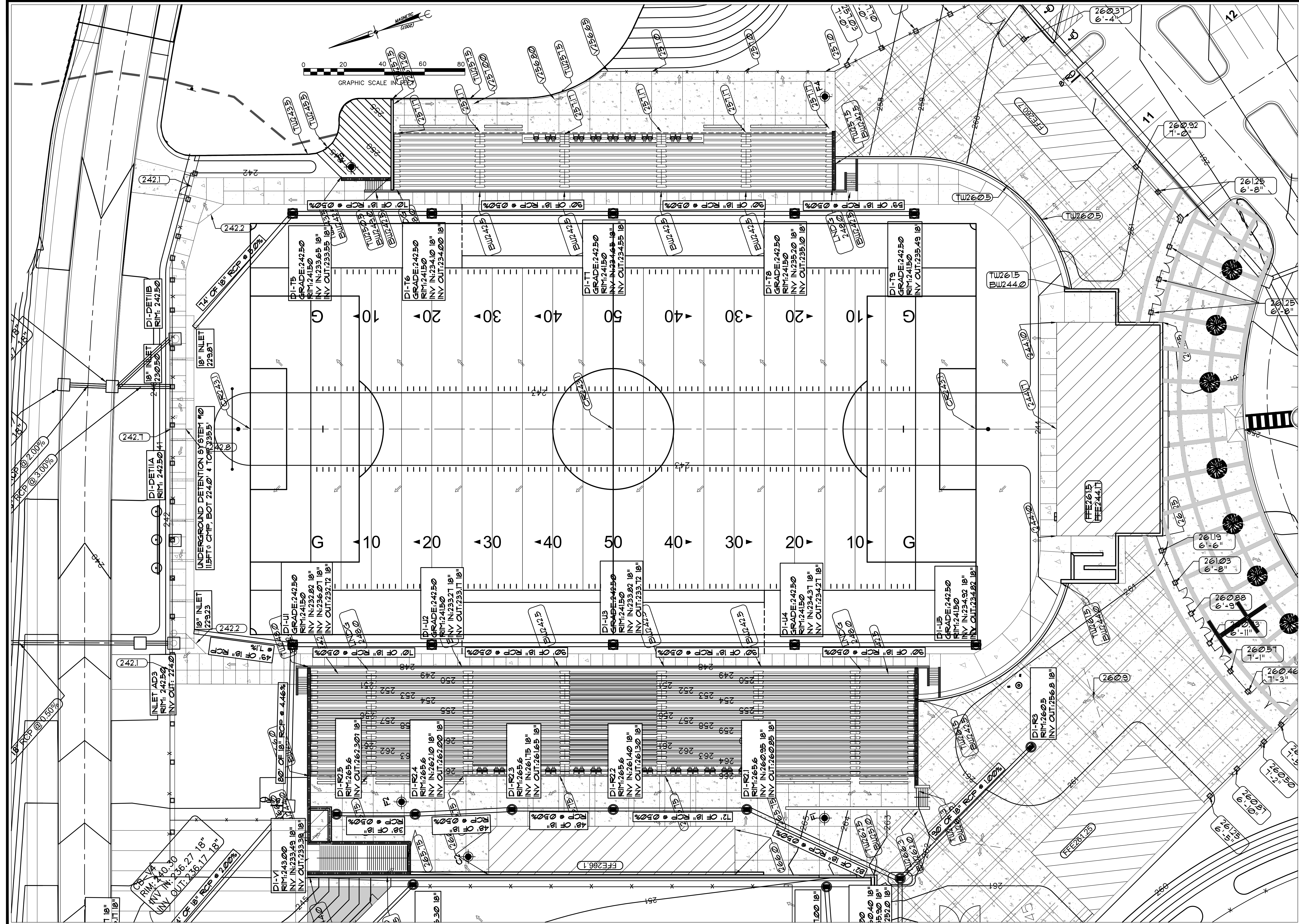

JACKSON
CIVIL ENGINEERING

221 Powell Drive
Lexington, SC 29072

SYNTHETIC TURF REPLACEMENT
RIVER BLUFF HIGH SCHOOL
320 CORLEY MILL RD, LEXINGTON, SC 29072
LEXINGTON SCHOOL DIST ONE

No	Description	Date

CONSTR DOCS

DRAWN BY: RPJ

CHECKED BY: JCE

PROJECT NO: 2402

DATE: JAN 2, 2024

SHEET TITLE:

GRADING AND STORM PLAN FOR REFERENCE

SHEET NO:

C203

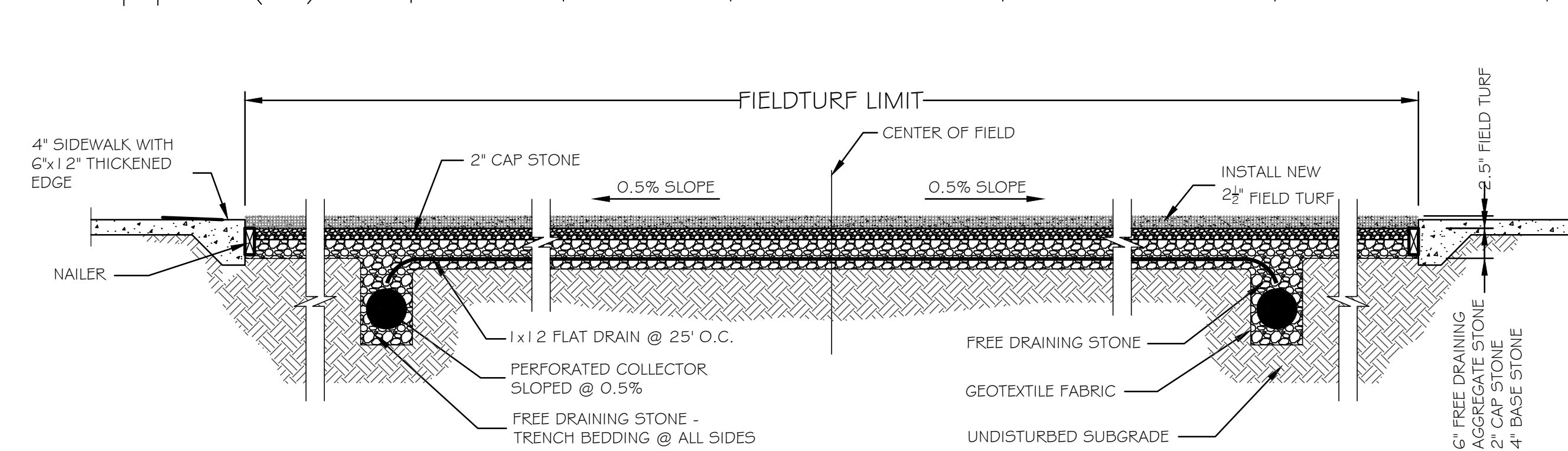
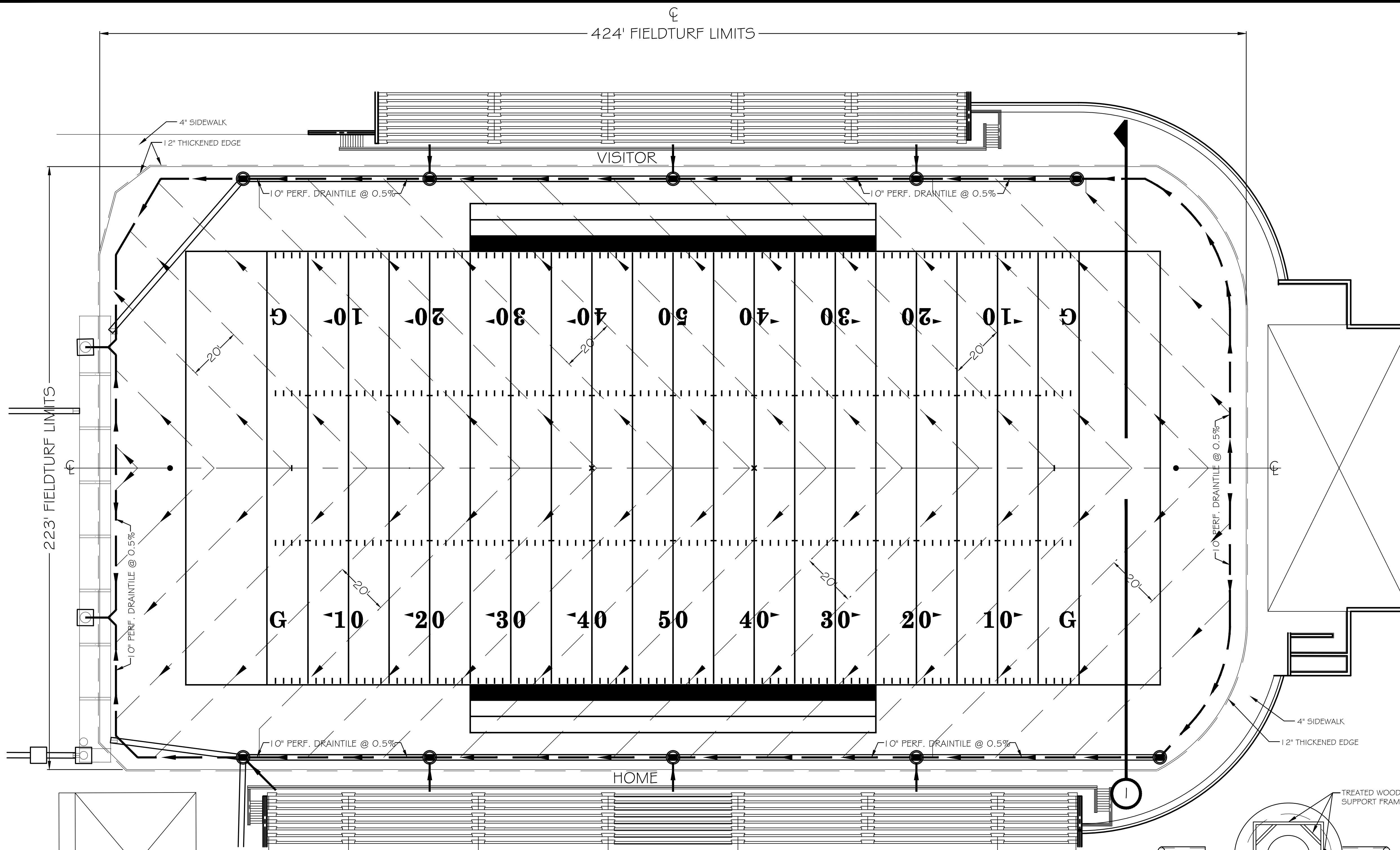

1 TRANSVERSE SECTION THROUGH EXISTING FIELD
N.T.S.

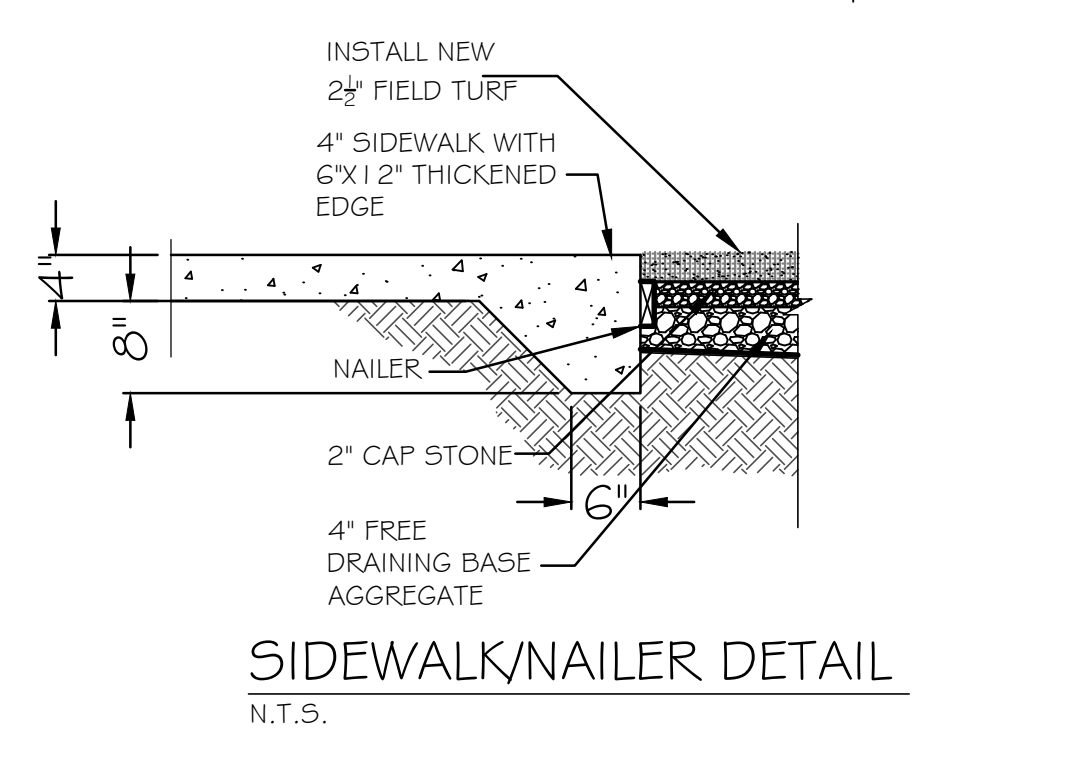

SIDEWALK/NAILER DETAIL
N.T.S.

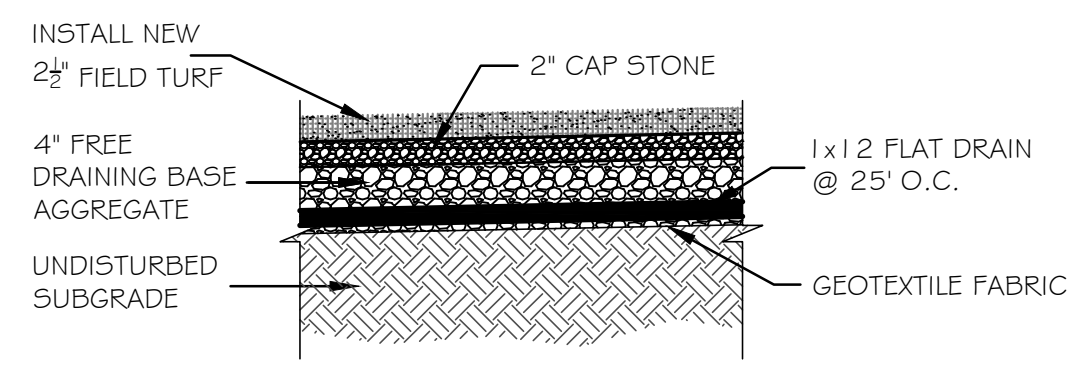

SUB DRAINAGE SYSTEM
N.T.S.

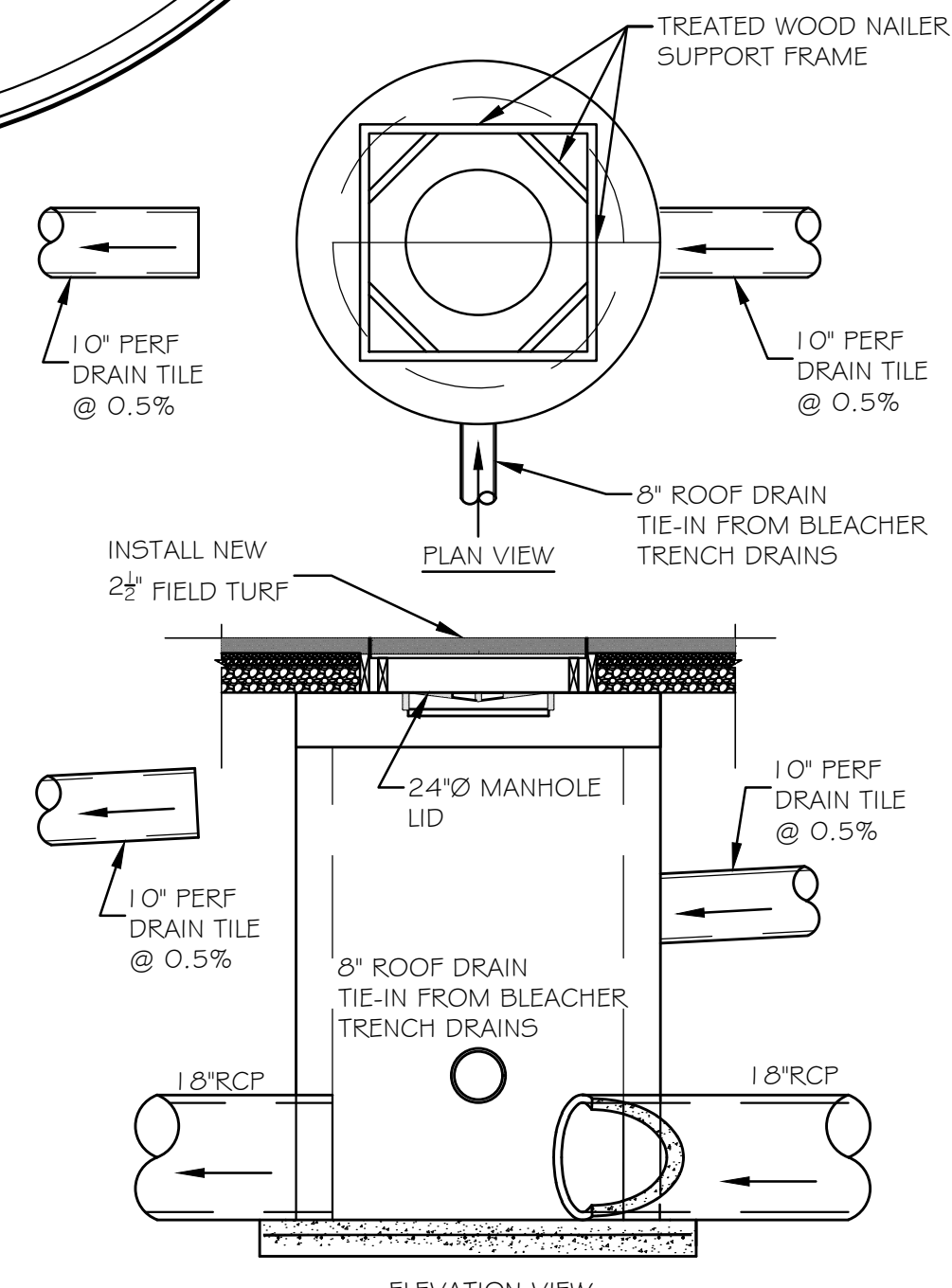

JUNCTION BOX DETAIL
N.T.S.

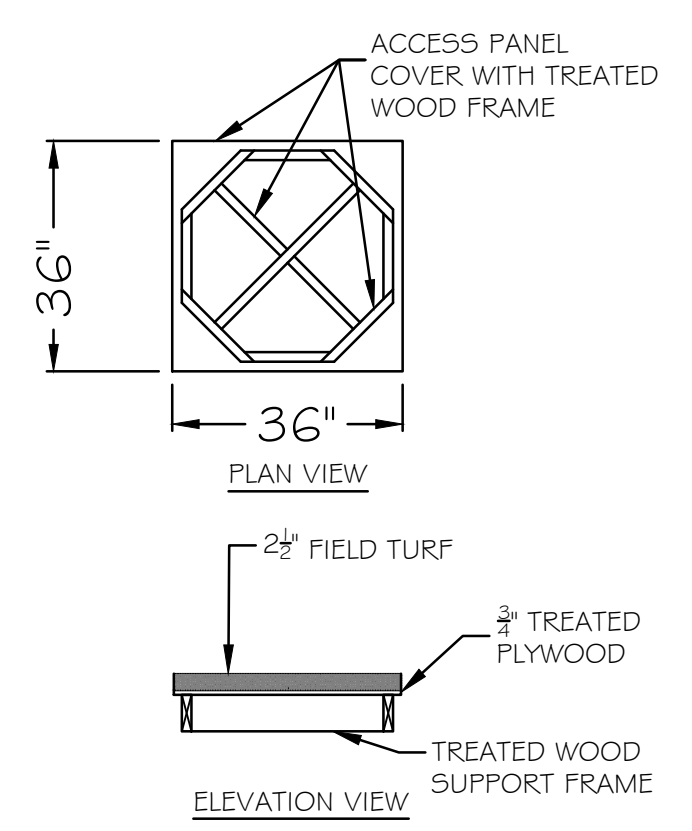

ACCESS PANEL DETAIL
N.T.S.

JACKSON
 CIVIL ENGINEERING
 221 Powell Drive
 Lexington, SC 29072

SYNTHETIC TURF REPLACEMENT
 RIVER BLUFF HIGH SCHOOL
 320 CORLEY MILL RD, LEXINGTON, SC 29072
 LEXINGTON SCHOOL DIST ONE

No	Description	Date

CONSTR DOCS
 DRAWN BY: RPJ
 CHECKED BY: JCE
 PROJECT NO: 2402
 DATE: JAN 2, 2024
 SHEET TITLE:

FOOTBALL FIELD
 SHEET NO: **C301**

ATTACHMENT C
MINORITY PARTICIPATION AFFIDAVIT

Is the bidder a South Carolina Certified Minority Business? Yes No

If yes, please list the SMBCC certification number: _____

Is the bidder a Minority Business certified by another governmental entity? Yes No

If so, please list the certifying governmental entity: _____

Will any of the work under this contract be performed by a SC certified Minority Business as a subcontractor?
 Yes No

If so, what percentage of the total value of the contract will be performed by a SC certified Minority Business as a subcontractor? _____

Will any of the work under this contract be performed by a minority business certified by another governmental entity as a subcontractor? Yes No

If so, what percentage of the total value of the contract will be performed by a minority business certified by another governmental entity as a subcontractor? _____

If a certified Minority Business is participating in this contract, please indicate all categories for which the Business is certified:

- Traditional minority
- Traditional minority, but female
- Women (Caucasian females)
- Hispanic minorities
- DOT referral (Traditional minority)
- DOT referral (Caucasian female)
- Temporary certification
- SBA 8 (a) certification referral
- Other minorities (Native American, Asian, etc.)

(If more than one minority contractor will be utilized in the performance of this contract, please provide the information above for each minority business.)

The Department of Administration, Division of Small and Minority Business Contracting and Certification, publishes a list of certified minority firms. The Minority Business Directory is available at the following URL:
<http://osmba.sc.gov/directory.html>

[04-4015-3]

ATTACHMENT D
OFFEROR'S CHECKLIST
AVOID COMMON MISTAKES!

(Review this checklist prior to submitting your offer)

- ✓ COMPLETED & SIGNED ALL REQUIRED DOCUMENTS.
- ✓ DO NOT INCLUDE ANY OF YOUR STANDARD CONTRACT FORMS!
- ✓ UNLESS EXPRESSLY REQUIRED, DO NOT INCLUDE ANY ADDITIONAL BOILERPLATE CONTRACT CLAUSES!
- ✓ MAKE SURE YOUR OFFER DOES NOT TAKE EXCEPTION TO ANY OF THE DISTRICT'S MANDATORY REQUIREMENTS!
- ✓ MAKE SURE YOU HAVE PROPERLY MARKED ALL PROTECTED, CONFIDENTIAL OR TRADE SECRET INFORMATION IN ACCORDANCE WITH THE INSTRUCTIONS: "SUBMITTING CONFIDENTIAL INFORMATION." DO NOT MARK YOUR ENTIRE RESPONSE AS CONFIDENTIAL, TRADE SECRET OR PROTECTED! DO NOT INCLUDE A LEGEND ON THE COVER STATING THAT YOUR ENTIRE RESPONSE IS NOT TO BE RELEASED!
- ✓ PROPERLY ACKNOWLEDGED ALL AMENDMENTS?
- ✓ MAKE SURE THAT YOUR OFFER INCLUDES THE SOLICITATION COVER PAGE. MAKE SURE THE COVER PAGE IS SIGNED BY A PERSON THAT IS AUTHORIZED TO CONTRACTUALLY BIND YOUR BUSINESS.
- ✓ MAKE SURE YOUR OFFER INCLUDES THE NUMBER OF COPIES REQUESTED.
- ✓ CHECK TO ENSURE YOUR OFFER INCLUDES EVERYTHING REQUESTED!
- ✓ IF YOU HAVE CONCERNS ABOUT THE SOLICITATION, DO NOT RAISE THOSE CONCERNS IN YOUR RESPONSE! AFTER OPENING, IT IS TOO LATE! IF THIS SOLICITATION INCLUDES A QUESTION & ANSWER PERIOD OR A PRE-SOLICITATION CONFERENCE, RAISE YOUR QUESTIONS AS PART OF THAT PROCESS.

This checklist is included only as a reminder to help offerors avoid common mistakes. Responsiveness will be evaluated against the solicitation, not against this checklist. You do not need to return this checklist with your offer.

SUBMIT WITH OFFER:

1. Cover Page
2. Page 2
3. Bid Schedule
4. Required information (Section V-Required Information)
5. BID BOND
6. Subcontractor Information
7. Minority Participation Affidavit

Completed W-9 (if needed)